

# PRECISION MAPPING

## Design and Testing of a Global Positioning System-Based Radiometer for Precision Mapping of Pearl Millet Total Dry Matter in the Sahel

Peter R. Lawrence, Bruno Gérard, Caroline Moreau, Fabrice Lhérieau, and Andreas Buerkert\*

### ABSTRACT

The nondestructive determination of plant total dry matter (TDM) in the field is greatly preferable to the harvest of entire plots in areas such as the Sahel where small differences in soil properties may cause large differences in crop growth within short distances. Existing equipment to nondestructively determine TDM is either expensive or unreliable. Therefore, two radiometers for measuring reflected red and near-infrared light were designed, mounted on a single wheeled hand cart and attached to a differential Global Positioning System (GPS) to measure georeferenced variations in normalized difference vegetation index (NDVI) in pearl millet fields [*Pennisetum glaucum* (L.) R. Br.]. The NDVI measurements were then used to determine the distribution of crop TDM. The two versions of the radiometer could (i) send single NDVI measurements to the GPS data logger at distance intervals of 0.03 to 8.53 m set by the user, and (ii) collect NDVI values averaged across 0.5, 1, or 2 m. The average correlation between TDM of pearl millet plants in planting hills and their NDVI values was high ( $r^2 = 0.850$ ) but varied slightly depending on solar irradiance when the instrument was calibrated. There also was a good correlation between NDVI, fractional vegetation cover derived from aerial photographs and millet TDM at harvest. Both versions of the rugged instrument appear to provide a rapid and reliable way of mapping plant growth at the field scale with a high spatial resolution and should therefore be widely tested with different crops and soil types.

MEASUREMENTS of reflected light have often been used for remote assessments of green biomass or physiological stresses in natural vegetation or agricultural plants (Tucker and Sellers, 1986; Zhu and Evans, 1992; Fernandez et al., 1994; Penulas et al., 1994). Red light is absorbed by the green chlorophyll pigments in photosynthetically active tissue and thus the proportion reflected varies inversely with the amount of plant material or biomass present. However, in the field, the intensity of reflected red light will depend not only on the proportion absorbed but also on its incident intensity that varies according to location and time of day. Practical methods of determining plant biomass usually take

this factor into account by simultaneously measuring at some other wavelength which is relatively unaffected by the presence of green material and expressing the results as a ratio of the two intensities. The most commonly used ratio is called the normalized difference vegetation index (NDVI) defined as

$$\text{NDVI} = (\text{NIR} - \text{RED}) / (\text{NIR} + \text{RED}) \quad [1]$$

where RED is the intensity of red ( $\lambda = 620\text{--}680$  nm) and NIR the intensity of near-infrared ( $\lambda = 790\text{--}900$  nm) reflected light.

Near-infrared (NIR) light is chosen as a reference because it is scattered by leaf surfaces as a result of the refractive index differences between intercellular air spaces and hydrated cells and is therefore almost unaffected by plant pigments (Colwell, 1974; Tucker and Sellers, 1986).

Although the interactions of red and NIR light with green plant material are very different, their reactions to most soil types are similar. For visible and NIR light, green leaves have albedos of 5 and 50%, respectively, whereas corresponding values for soils are 8 and 11% (Carlson and Ripley, 1997). Consequently, NDVI values range from around zero for bare earth to 0.8 for lush green pasture. To account for differences in soil reflectance due to moisture and texture, various soil adjusted vegetation index (SAVI) equations have been proposed (Huete et al., 1985; Neale et al., 1989; Bausch, 1993).

For the accurate nondestructive estimation of millet dry matter in the Sahel, a simple hand-held radiometer for measuring reflected light or radiometer has been previously described (Buerkert et al., 1995). After proper calibration, this instrument could be used for the rapid sampling of individual young millet plants in experimental plots or the assessment of biomass gradients in a field. However, the plant samples chosen for calibration needed to be carefully selected to reflect the range of plant sizes in a plot and this required time and careful observation. Given the widespread availability of GPS the aim of this research was to design a radiometer that could be connected to a differential GPS to measure all plants in a given field, relate the reflectance

P.R. Lawrence, Inst. of Animal Production in the Tropics and Subtropics (480); B. Gérard and F. Lhérieau, International Crops Research Institute for the Semi-Arid Tropics (ICRISAT) Sahelian Center, B.P. 12404, Niamey, Niger; C. Moreau, Unité écologie des grandes cultures, Université Catholique de Louvain, Place Croix du Sud, 2 Bte 11, 1348 Louvain-la-Neuve, Belgium; A. Buerkert, Inst. of Plant Nutrition (330), Univ. of Hohenheim, D-70593 Stuttgart, Germany; presently Inst. of Crop Science, Univ. of Kassel, D-37213 Witzenhausen, Germany. Received 25 Mar. 1999. \*Corresponding author (buerkert@wiz.uni-kassel.de).

**Abbreviations:** TDM, total dry matter; GIS, Geographic Information System; GPS, Global Positioning System; NDVI, normalized difference vegetation index; NIR, near-infrared; SAVI, soil adjusted vegetation index; LED, light emitting diode; V/F, voltage to frequency; UART, universal asynchronous receiver/transmitter; LCDs, liquid crystal displays; DAS, days after sowing.

measurements to the corresponding plant positions and subsequently to process the data to obtain a dry matter map for the entire area measured. Such an instrument should be a valuable tool for agricultural research in an environment such as the Sahel where large spatial variability in plant growth within short distances often masks treatment effects unless large-scale (and time consuming) destructive sampling is performed. Once developed and prototyped, two versions of the new instrument were tested (i) to verify the correlation between NDVI and pearl millet TDM obtained by Buerkert et al. (1995); (ii) to refine the sensor calibration procedure to account for different solar irradiance levels and soil conditions; (iii) to test the suitability of georeferenced NDVI measurements for the production of crop growth maps taking into account the spatial variability of millet growth, and (iv) to optimize radiometer settings such as sensor height and measurement intervals for various pearl millet growth stages.

## MATERIALS AND METHODS

In both radiometers made for this study, reflected light was detected using two light emitting diode (LED) sensors, one maximally sensitive to red light of wavelength 660 nm and the other to NIR light of 880 nm wavelength. The first of the two radiometers (instrument 1 for discrete NDVI measurements) gave a series of discrete 'spot' measurements of NDVI at fixed intervals of 0.03 to 8.53 m settable by the user. This instrument was most suitable for use in millet fields where three to five plants are grown together in discrete planting hills or pockets. The pockets were arranged in rows 1 and 2 m apart. Care was taken to ensure that the area viewed by the sensors or footprint was large enough to cover all the plants in a pocket. The second radiometer for averaged NDVI measurements gave values of NDVI averaged every 0.5, 1.0, or 2.0 m and was found to be more appropriate for estimating the biomass of plants whose ground cover varies slowly and continuously such as new grasslands at the beginning of the rainy season. Average values made in this way are not suitable for discrete plants such as millet since an unpredictable and often disproportionate number of the readings that go to make the average value can come from bare earth rather than plant material.

### Description of the Instruments

#### Features Common to Both Radiometers

Both devices have a main processing unit powered by two rechargeable 12 V, 1.2 Ah lead gel batteries, that supply enough current for about 7 d of normal operation. The processing unit and batteries are housed in a sturdy plastic (PVC) box of 0.21 by 0.10 by 0.22 m. The box is strapped to a light metal frame in the general shape of a wheelbarrow with a 0.637 m diam. bicycle wheel at the front and two supports at the back (Fig. 1). The bicycle wheel is fitted with an axially mounted, sealed odometer unit containing a slotted disc and an opto switch, that produce 60 square wave pulses per revolution of the wheel, that is, one pulse for every 33.3 mm of forward movement.

The two LED sensors used were types ER-300 and XC880A (Gallium Aluminium Arsenide) which are maximally sensitive to red light of wavelength 660 nm and NIR light of wavelength 880 nm. They are 5 mm in diameter and 7 mm long and are mounted side by side in the center of a 50 mm diam. plastic

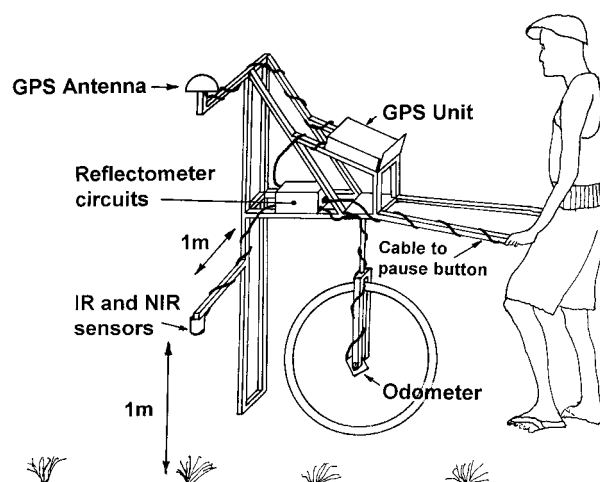

Fig. 1. Diagram of the radiometer operating in a pearl millet field showing its major components.

tube 50 mm from the opening giving a sensor view angle of about 53°. The tube was painted matt black and attached vertically on a horizontal boom 1 m to the center right of the main frame. Reflectance measurements were normally taken with the sensors 1 m above ground level giving the sensors a circular footprint of about 0.5 m radius. Changing the sensor height produced corresponding changes in the scanned area.

The wheelbarrow design with the sensors projecting to one side minimized the risk of damage to the plants being scanned and the chances of shadows or strong reflected light affecting the outputs of the sensors. It also ensured that the sensors remained at an almost constant height above the ground. When used for scanning large areas, the instruments were pushed along at normal walking speeds of between 0.5 and 1.0 m s<sup>-1</sup>. The odometer and the LEDs send their respective signals back to the main processing unit via screened cables. In both versions of the apparatus, small currents in the nanoampere range from the red and infrared LEDs are first converted by operational amplifiers to proportional voltages (Fig. 2), which are then fed into an analogue multiplier/divider (Type AD734; Analog Devices, Norwood, MA) to produce an output voltage proportional to the NDVI. The gain of the amplifier which processes the signal from the infrared LED can be adjusted by altering the value of its feedback resistor using a potentiometer mounted on the front of the instrument so that the NDVI can be set to zero, that is, the outputs of the amplifiers can be equalized when the instrument is set up as described below.

It should be noted that this adjustment affects only the gain of the amplifier and not the offset which is zero volts for both amplifiers. This ensures that the same ratio of RED and NIR light intensity will always give the same NDVI value regardless of the total intensity of the incident light.

The display, which indicates when the zero point has been reached, differs between the two instruments. In instrument 1, the "discrete measurement" device, it is a precision LCD voltmeter connected to the output of the analogue multiplier via an attenuator circuit adjusted so that the voltmeter registers the actual NDVI value and can thus be used as a visual check on the data sent to the GPS system. In the other instrument, a much cheaper moving coil null indicator activated by a push switch was used. A visual display of the NDVI is available elsewhere in the circuit on a counter but this is not usable as a null indicator. The output from the analogue

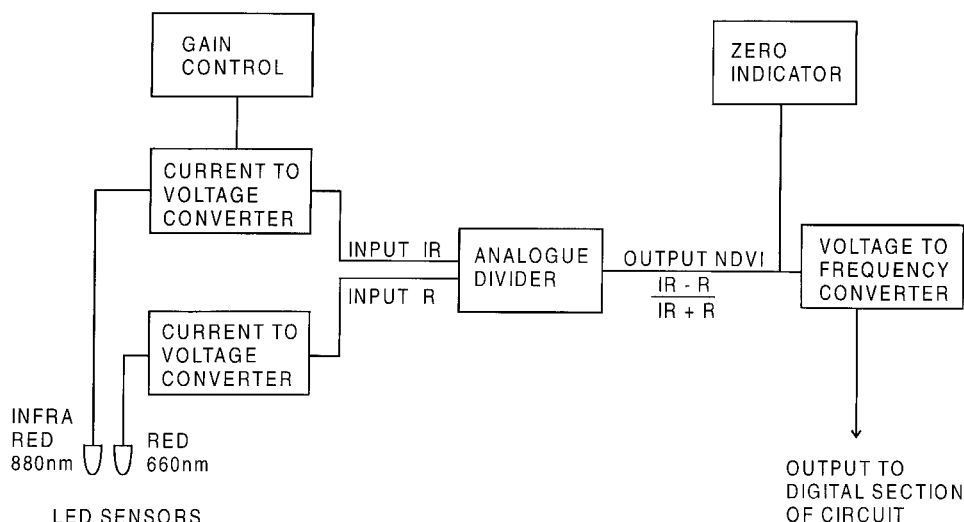

Fig. 2. Block diagram of circuitry common to both versions of the radiometer.

multiplier is next fed into a voltage to frequency (V/F) converter that produces a square wave output whose frequency is proportional to the input voltage. This digital frequency is then processed in different ways in the two versions of the instrument. Each instrument with its odometer unit weighs about 2 kg, and takes 50 to 60 person-hours to make. The total cost of components is currently about U.S. \$400. All components are available from RS Components, Corby, Northamptonshire, UK.

#### Instrument 1 for Discrete Normalized Difference Vegetation Index Measurements

The square wave input from the odometer is divided by a number from 1 to 256 settable by 8 digital switches mounted on the front panel (Fig. 3A). The divider thus outputs one pulse at equal distances from 33 to 8525 mm according to the setting of the switches. The actual number set by the digital switches is repeatedly displayed on a counter-display. The rising edge of the output pulse from the divider is used to generate a precision pulse that allows the digital signal from the V/F converter through a NAND gate for exactly  $1.667 \times 10^{-3}$  s. The analogue multiplier and V/F converter are set so that the number of pulses coming through the NAND gate in this time is equal to the NDVI value multiplied by 200. Thus NDVI values in the normal range of 0 to 0.8 will produce 0 to 160 pulses. These pulses are temporarily stored in a buffer in the serial link. The falling edge of the output pulse from the divider triggers the universal asynchronous receiver/transmitter (UART) in the serial link to transmit the stored NDVI value in serial format as a single 8 bit number to a data logger or a portable computer. In the experiments reported here, the logger TDC1 Asset Surveyor was part of the GPS (Trimble Pathfinder ProXL). Note that at normal walking speeds, ( $0.5$ – $1.2 \text{ m s}^{-1}$ ) the NDVI value is unaffected by the speed at which the radiometer sensors scan the ground. Even if readings were taken every 33 mm the instrument would have to be traveling at nearly  $10 \text{ m s}^{-1}$  before the length of half the trigger pulse would be short enough to interfere with the transmission of the NDVI value. The switch shown on the diagram just after the serial link is fixed to the handle of the frame on which the radiometer is mounted so the operator can interrupt the signal and avoid the storage of unwanted data.

#### Instrument 2 for Averaged Measurements

This version of the radiometer can operate in two modes (modes 1 and 2) that do not require a data logger because the results are displayed on liquid crystal displays (LCDs) and can be noted by the user. In addition, and independently of whether the instrument is set to mode 1 or 2, it outputs NDVI values averaged every 0.5, 1.0, or 2.0 m (settable by the user) that can be recorded on a GPS or other data logger. The averaged NDVI values are derived from individual measurements taken every 33.3 mm. In mode 1, the instrument displays the cumulative total of all the NDVI readings on one display and the total distance traveled (m) on another. The average NDVI along any distance can thus be calculated by dividing the first figure by the second. In mode 2, the instrument measures NDVI values within a 10-m long strip of ground and displays the average at the end. Pushing a button on the front panel clears the display and enables another 10 m average to be measured. The sequence of events that produces the output for the GPS data logger starts when the odometer triggers a pulse from the precision pulse generator. This pulse is used to gate through the digital signal from the V/F converter for exactly  $4.00 \times 10^{-3}$  s (Fig. 3B). The pulses comprising this signal are then divided by 128, 256, and 512, and the outputs are sent to one side of a three-way, two-pole rotary switch, the other side of which receives pulses from the odometer via dividers which occur at 0.5, 1, and 2 m intervals, respectively. The proportionality between NDVI values and the distance over which the data are collected is thus maintained regardless of the setting of the rotary switch, that is, the NR pulses are divided least when the distance is smallest and vice versa. The distance pulses also provide the triggers for the transmission of the averaged NDVI values by the serial link to the GPS data logger as for discrete measurements.

#### Processing of Georeferenced Reflectometric Data

Data from the radiometers can arrive at the GPS data logger at any time and so are unlikely to coincide exactly with the positional readings that the GPS takes itself. Such data are known as asynchronous or “unsolicited” and when a NDVI value is sent as an ASCII character to the GPS through the serial link, the TDC1 Asset Surveyor records it along with the two GPS positions that “bracket” the value. The GPS also

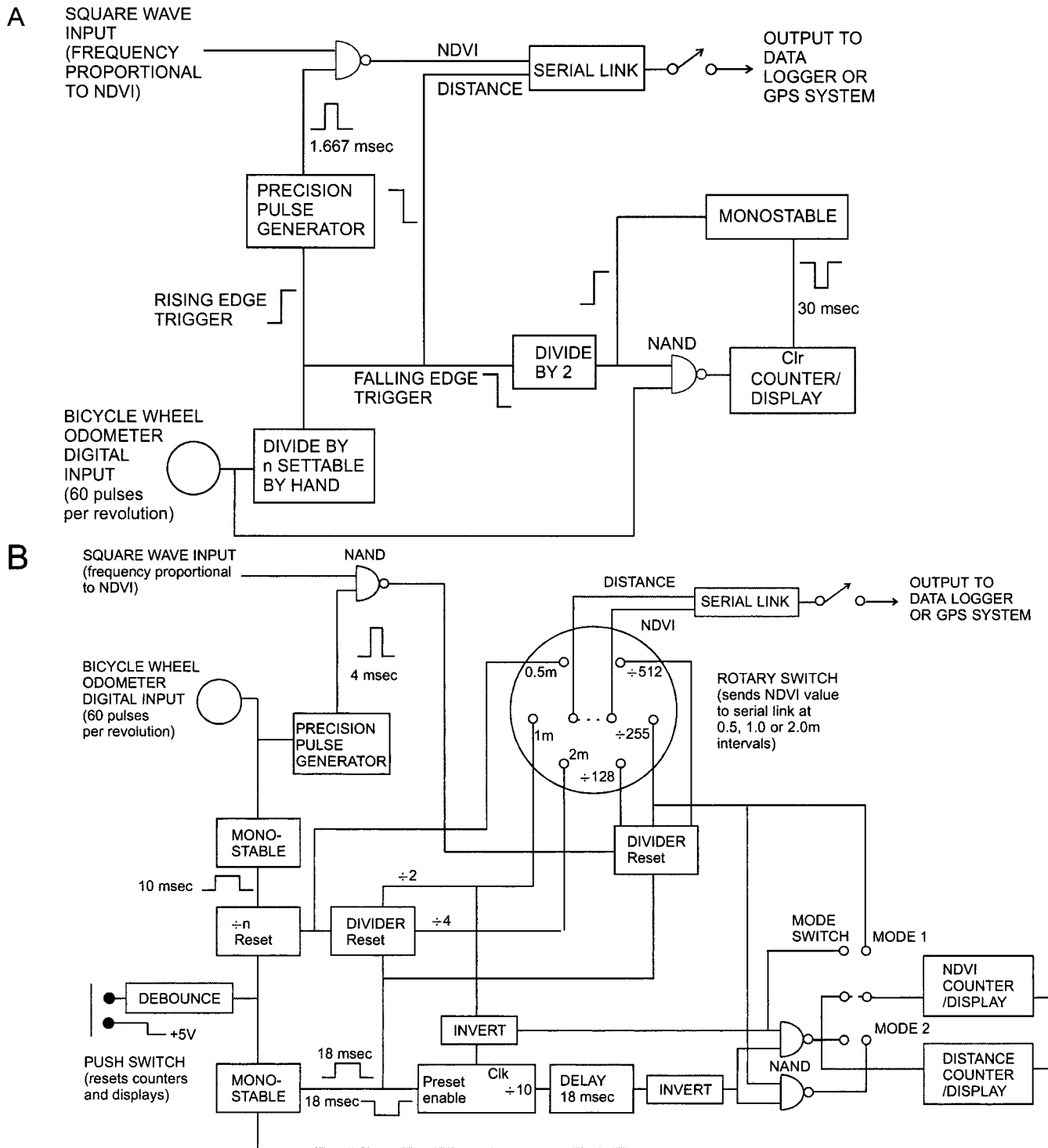

Fig. 3. Block diagram of the digital processing circuitry for the 'discrete measurement' (instrument 1) radiometer (A) and block diagram of the digital processing circuitry for the 'continuous measurement' (instrument 2) radiometer (B).

records the times at which the NDVI value arrived and the positional readings were taken. The exact location of the NDVI reading is calculated later by interpolation, assuming that the speed at which the radiometer traveled between the two GPS readings was constant.

To maximize the accuracy of the GPS readings, data were differentially corrected using a GPS base station within 500 m distance to produce a longitude, latitude, ASCII NDVI text

file which gave a positioning precision of NDVI measurements of  $\pm 0.2$  m. A Pascal program was written to convert ASCII NDVI values into integer values. The resulting files were imported into ArcView software for further processing and data analysis. For the continuous measurement radiometer (instrument 2), the GPS positions recorded for the NDVI measurements averaged along 0.5, 1.0, and 2.0 m needed correction because they were taken only after the average NDVIs had

**Table 1. Normalized difference vegetation index (NDVI) measurements over bare soils and solar irradiance at dates and times of vegetation sampling in trial 1 at Sadoré, Niger, 1998.**

Date	Time	NDVI of bare soil: Before measurements		NDVI of bare soil: After measurements		Solar irradiance	Solar angle
		Tilled	Untilled	Tilled	Untilled		
22 June	1100–1200	0.26	0.27	0.26	0.27	786	56–69
23 June	1100–1200	0.26	0.27	0.25	0.26	909	56–69
24 June	1000–1100	0.26	0.27	0.25	0.26	753	48–56
25 June	1000–1100	0.36	0.38	ND†	ND	157	48–56
26 June	1000–1100	0.26	0.27	0.24	0.27	704	48–56
30 June	1400–1500	0.21	0.23	ND	ND	927	62–49

† ND = no data available.

been transferred to the GPS. The correct positions were obtained by averaging the latitudes and longitudes of the actual NDVI measurement and those of the previous one.

### Setting Up the Radiometer Sensors

Three factors determined the nature of the set up procedure used for these instruments, (i) no standard light sources were available for use in the field which would provide constant photon or energy fluxes of light in the RED and NIR wavebands for calibration purposes. It was therefore not possible to calibrate the instruments to give absolute readings of NDVI; (ii) all experimental measurements were taken over light colored sandy soils which, when devoid of plant material had small NDVI values which varied slightly between plots (Table 1); (iii) although the NDVI values of the bare soil were small, they did make a significant contribution to the overall NDVI because the majority of readings were taken in places where the plant cover was <50%.

With these points in mind, it was decided to set the instrument to give an NDVI reading of zero when it was taking measurements over bare soil, that is, to use the soil itself as the reference. Any observed increases in NDVI would then be due to plant material. In practice this proved awkward because of the variations in soil NDVI between plots and because an instrument set to zero over soil will occasionally give small negative readings which could not be handled by the automatic data collection circuitry in the GPS system. The instrument was therefore set to give an NDVI reading of zero under other, reproducible conditions, and the NDVI values of bare soil were removed using the formula

$$\text{NDVI}_{\text{corr}} = \frac{(\text{NDVI}_{\text{total}} - \text{NDVI}_{\text{soil}})}{(1 - \text{NDVI}_{\text{total}} \times \text{NDVI}_{\text{soil}})} \quad [2]$$

where  $\text{NDVI}_{\text{corr}}$  is the corrected NDVI,  $\text{NDVI}_{\text{total}}$  is the NDVI measured over plants and  $\text{NDVI}_{\text{soil}}$  is the NDVI measured over bare soil. The rationale behind this formula and its derivation are given in the Appendix.

In common with other scientists (Buerkert et al., 1995; Nageswara et al., 1991) the conditions chosen for the initial set up of the radiometers were as follows. The sensors were held with the diodes 0.3 m vertically above a matt white sheet of paper exposed in bright sunlight without shadows at around solar noon. The white paper approximated a 'Lambertian' surface and once the NDVI reading had been set to zero by adjusting the gain of the NIR LED current-to-voltage converter as described above, the radiometers gave small but positive NDVIs over all the soils in the experimental plots. The lack of absolute NDVI values did not lessen the utility of the radiometers for estimating plant biomass.

### Field Measurements

Both versions of the radiometer were tested, during 1998, on several millet field experiments at the ICRISAT Sahelian Center at Sadoré, Niger (13°14'N, 2°17'E). The acid, sandy soil of this area was classified as a Psammentic Paleustalf or Arenosol by West et al. (1984).

#### Trial 1

A series of three experiments (trial 1) were performed with instrument 1 in a 1.5-ha water/nutrient response trial during the 1998 dry season. This experiment was chosen as a testing ground for the instrument because the spatial variability in millet growth was high. The area studied was a rectangle 35 by 10 m divided into 14 plots of 5 by 5 m sown on 20 March with landrace millet at a plant spacing of 1 by 1 m.

#### Experiment 1a: Validation of Normalized Difference Vegetation Index Measurements by Aerial Photography

Georeferenced radiometer measurements were taken of the whole 35 by 10 m area at 0.4 m intervals along the rows on 13 May, 54 d after sowing (DAS) followed by the taking of a high resolution aerial photograph at 100 m height of the whole area 2 d later as described by Gérard et al. (1997). The photograph was scanned at 300 dpi equivalent to a ground pixel resolution of 0.04 m, georeferenced and geometrically corrected in ArcInfo using ground control points (Fig. 4). The red band of the image was converted into an ArcView grid and a threshold reflectance value was set to differentiate between vegetation and sandy soil. Plot layouts were digitized on screen in ArcView and the ArcView Spatial Analyst module was used to derive the fractional vegetation cover from the aerial photograph, that is, the percentage of grid elements per plot classified as vegetation. The 13 May georeferenced radiometer data from the same trial were averaged at the plot level (45–60 NDVI measurements per plot) and the correlation between plot NDVI and fractional vegetation cover was examined.

#### Experiment 1b: The Influence of the Level of Solar Irradiance on Normalized Difference Vegetation Index Measurements and the Correlation of Normalized Difference Vegetation Index and Total Dry Matter

Radiometer measurements were taken daily from 22 to 26 June, on a subset of the 35 by 10 m area (two consecutive lines of 20 plants) at 0.4-m intervals to assess the influence of the level of solar irradiance on NDVI measurements. Total solar irradiance was measured with a LI2000S silicon pyranometer (LI-COR Inc., Lincoln, NE). On 1 July, the 40 plants were harvested and oven dried at 65°C to constant weight for TDM determination. Normalized Difference Vegetation Index measurements of bare soil were taken before and after

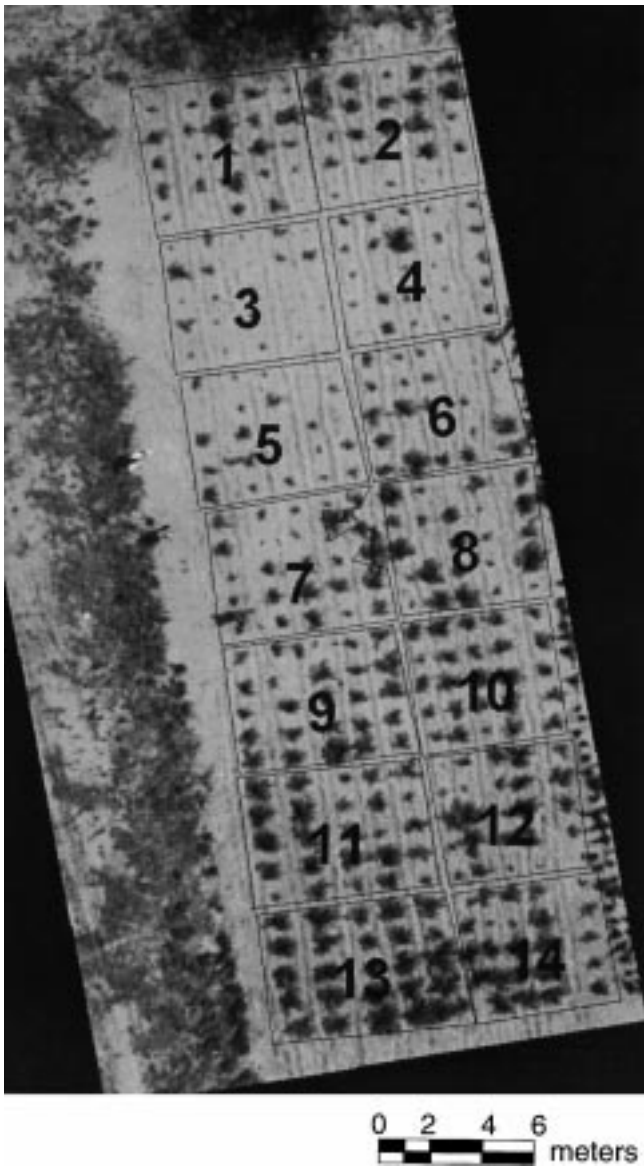

Fig. 4. Georeferenced red band of the aerial photograph taken on 15 May 1998 of the subarea of trial 1 used for the radiometer calibration. The plot layout and positions of radiometer measurements overlays are shown.

each measuring session (Table 1) and used to apply corrections as described above.

#### Experiment 1c: A Comparison of Normalized Difference Vegetation Index Measurements Taken Automatically at Regularly Spaced Intervals with Spot Measurements Over Individual Plants

This experiment was designed to see how well radiometer measurements taken at regular intervals recorded the maxima in NDVI that occur in fields containing “pockets” of young millet plants. Georeferenced NDVI measurements were made on 30 June on a different subset of the 35 by 10 m area (two consecutive lines of 20 plants) and at sampling intervals of 0.1, 0.2 as well as 0.40 m and compared with nongeoreferenced radiometer measurements taken by positioning the sensor directly above each of the 40 plants at a height of 1 m. The NDVI measurements of bare soil were taken before and after

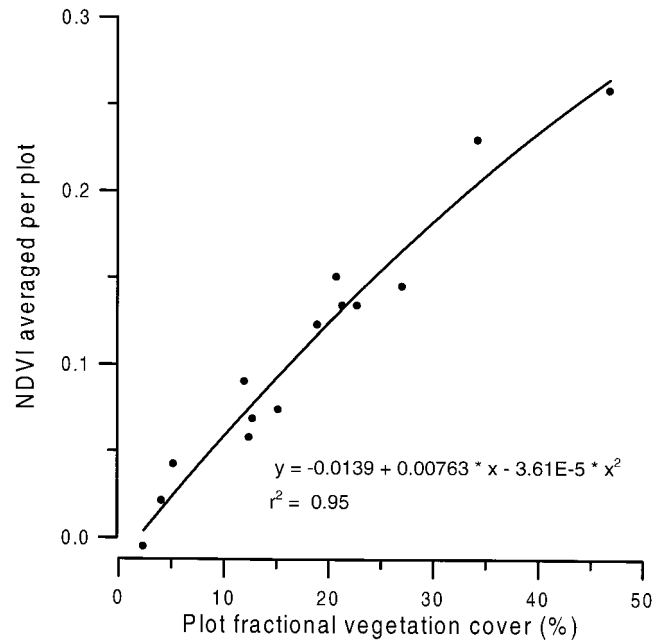

Fig. 5. Relationship between plot fractional vegetation cover determined from aerial photography and normalized difference vegetation index (NDVI) values from radiometer measurements.

each measuring session (Table 1) and used to apply corrections as described above.

#### Trial 2

A second series of measurements (trial 2) was made with instrument 2 in a 1 ha seed multiplication field of pearl millet variety SOSAT C88. The plants were sown on 4 Feb. 1998, at intervals of 0.8 m on ridges 0.75 m apart and regularly irrigated to avoid water stress. The radiometer was set to transmit average NDVI values every 2 m, equivalent to two pockets of millet, to the GPS data logger. Measurements were taken on every second millet row at three dates (43 DAS, 51 DAS, and 57 DAS) at a sensor height of 1.5 m. Straw, head, and grain dry weight data at harvest (93 DAS) were taken on a 16 by 16 plant grid to produce a yield map of the field that could be compared with a similar map derived from the NDVI measurements.

## RESULTS AND DISCUSSION

### Trial 1: The Relationships between Pearl Millet Normalized Difference Vegetation Index Measurements with Instrument 1, Aerial Photography, and Total Dry Matter

#### Experiment 1a: Validation of Normalized Difference Vegetation Index Measurements by Aerial Photography

The radiometer measurements taken on 13 May every 0.4 m at 1 m height in rows approximately 1 m apart were compared with the fractional vegetation cover extracted from the 15 May aerial photograph (Fig. 4). The relationship found was a second degree polynomial with  $r^2 = 0.94$  (Fig. 5). The strong correlation between fractional vegetation cover and NDVI averaged per 5 by 5 m plot suggests that even if the instrument gives poor results for measurements on individual plants (see ex-

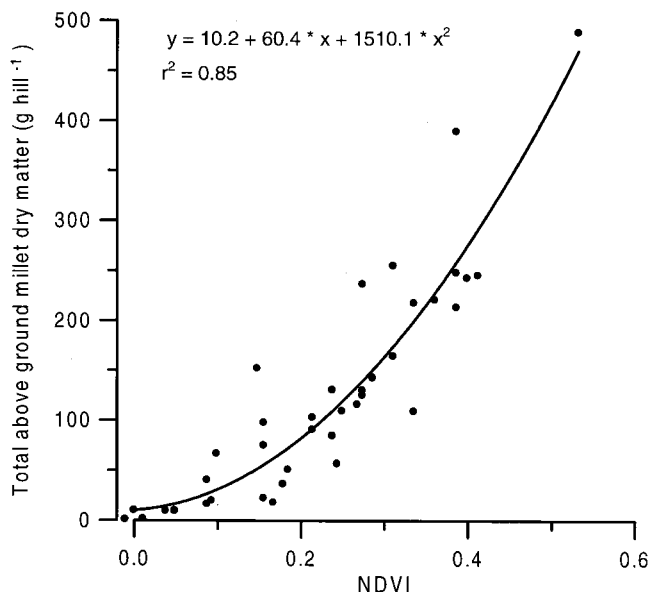

Fig. 6. Relationship between above ground total dry matter (TDM) of individual millet hills and normalized difference vegetation index (NDVI) taken on 24 June 1998 in trial 1.

periment 1c below), average NDVI values at the plot level may provide reliable data. This showed the potential of the instrument for making plant growth variability maps and monitoring the dynamics of plant growth in experiments or in farmers' fields.

#### Experiment 1b: The Influence of the Level of Solar Irradiance on Normalized Difference Vegetation Index Measurements and the Correlation of Normalized Difference Vegetation Index and Total Dry Matter

The daily measurements for the 5 d period (22–26 June or 94–99 DAS) in trial 1 were used to verify the relationship between NDVI measurements from the radiometer and pearl millet TDM because, owing to the inherent field variability and different treatments, the plants had a large range of biomass and were at various phenological stages. The relationship between the TDM of individual millet pockets and their respective NDVI values was found to be nonlinear (Fig. 6) but followed a second degree polynomial instead of the exponential model used by Buerkert et al. (1995). The  $r^2$  values obtained for the polynomial model ranged from 0.70 for a cloudy day (25 June) to 0.85 with an average of 0.78 for the five series of measurements. To allow for differences in incident solar irradiance, all the NDVI values taken over plants during a particular measurement session were adjusted for the appropriate initial NDVI value over bare soil (Table 1) using the formula given under 'Setting up the radiometer sensors'. This adjustment proved satisfactory for all series of measurements taken during sunny days (solar irradiance  $R_a$  ranging from 704–909  $W m^{-2}$ ) and the resulting regression polynomials were very similar to each other (Fig. 7). For the series of measurements taken during a cloudy day under diffused light ( $R_a$  of 157  $W m^{-2}$  on 25 June), the regression on the adjusted NDVI was similar to those obtained

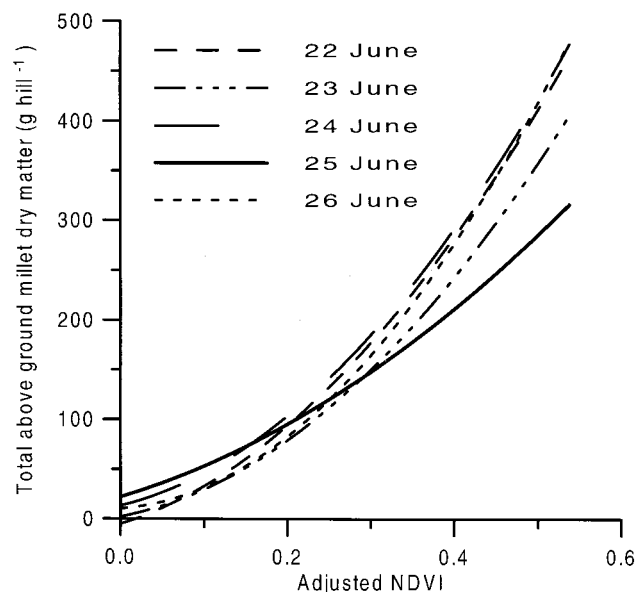

Fig. 7. Comparison of regression polynomials measured for 5 consecutive days during experiment 1b after correction of the normalized difference vegetation index (NDVI) values for the background NDVI of bare soil.

on sunny days but the curve was flatter (Fig. 7). The adjustment also proved satisfactory whether the correction was made for tilled or non-tilled bare soil (Table 1) even though there was a small but significant difference (pairwise  $t$ -test,  $P < 0.001$ ) between the NDVIs measured over the two surfaces.

A final set of measurements taken at intervals of 0.1, 0.2, and 0.4 m on 30 June (not shown in Fig. 7) gave a poorer correlation with the TDM of individual plants than those obtained previously. This probably occurred because by this time the plants were so high that the sensors had to be raised to 1.5 m above ground level. This made it difficult to obtain measurements with the plants exactly in the center of the sensor's footprint. However, even when these regularly spaced measurements were processed manually to extract the local NDVI maxima corresponding to the plant centered radiometer measurements, the NDVI maxima and the corresponding individual pocket TDMs were poorly correlated. In fact, the polynomial  $r^2$  was  $< 0.5$ , which shows that by this stage of plant growth, the instrument had reached its limit for reliably estimating the final TDM of individual plants.

#### Experiment 1c: A Comparison of Normalized Difference Vegetation Index Measurements Taken Automatically at Regularly Spaced Intervals with Spot Measurements Over Individual Plants

The choice of the distance between measurements when using radiometer 1 is a compromise between the precision required and (on large plots) the storage capacity of the GPS data logger. These results (Fig. 8) give no clear indication that a 0.1 m spacing gives a sharper NDVI curve (and is therefore better for detecting NDVI maxima) than spacings of 0.2 or 0.4 m. This is perhaps not surprising since the width of the

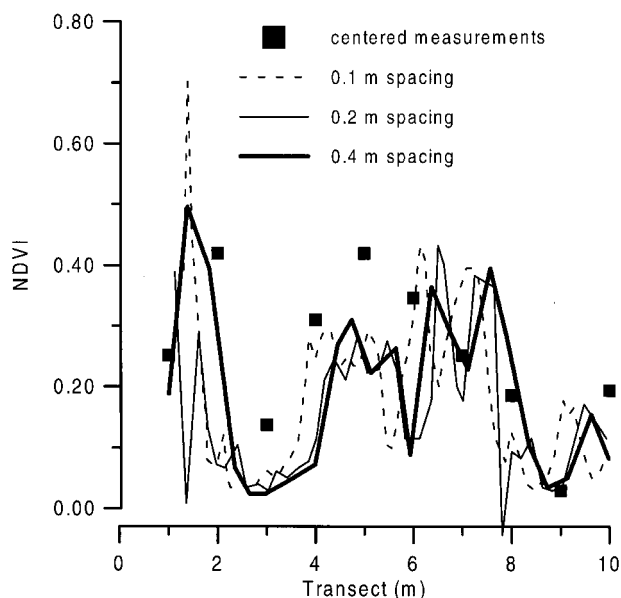

Fig. 8. Transect of regularly spaced (0.1, 0.2, and 0.4 m) normalized difference vegetation index (NDVI) measurements over 10 millet hills compared to NDVI measurements centered over plants on 30 June 1998, experiment 1c.

instrument's footprint (1 m) is more than twice the largest interval tested and so consecutive measurements will overlap by more than 50%. It may well be possible to use intervals of  $>0.4$  m without loss of precision thereby saving even more data storage space. The slight shift between the curves in Fig. 8 is most likely caused by the imprecision in the GPS positioning of  $\pm 0.2$  m.

### Trial 2: The Relationship between Yields of Pearl Millet at Harvest and Normalized Difference Vegetation Index Measurements Taken with Instrument 2

The correlation between harvest data and radiometer NDVI values taken at 43, 51, and 57 DAS and aggregated on a 16 by 16 plant grid was highly significant for all three dates. The best fits for head yield ( $r^2 = 0.64$ ) and for straw yield ( $r^2 = 0.43$ ) were obtained with a multiple linear regression using NDVI values at 43 and 57 DAS. The relatively low correlation obtained between yields and NDVI measurements can be partially explained by the time lag (36 d) between the last NDVI measurements and harvest. The NDVI image obtained in ArcView by interpolating NDVI measurements (Fig. 9) enabled the microvariability in plant growth to be assessed and suggested a slight growth gradient from east to west. This gradient may have been caused by an irrigation deficit at the east edge of the field that resulted in slower plant growth but greater production of plant tillers under the prevailing conditions of mild water stress (Mahalakshmi and Bidinger, 1986). Visual inspection of the field showed that the instrument accurately recorded the variability in crop growth.

### Comparison with Other Nondestructive Methods

Other nondestructive methods such as the LI-COR LAI-2000 plant canopy analyzer (Hicks and Lascano,

1995; Welles and Norman, 1991) or aerial photography (Blackmer et al., 1996; Gérard et al., 1997) have been successfully used for the quantitative estimation of the plant canopy of various crops. No results have so far been published for nondestructive measurements of millet with the canopy analyzer, but the equipment has been tested at ICRISAT Sahelian Centre in several experiments (Biielders, personal communication, 1999) in which it was found that several aspects of this instrument made it difficult to use for this particular crop and location. The vegetation in the canopy of millet is sparse, and unevenly distributed and the optical sensor of the canopy analyzer must be placed under the canopy. It is therefore difficult to move the sensor around quickly and in a systematic way to get sufficient georeferenced measurements to map the variations of biomass in a highly heterogeneous millet field. With the radiometer described here on the other hand it is relatively easy to take the thousands of NDVI measurements per hectare that appear to be necessary to capture plant growth variability. In addition, the canopy analyzer must be used in diffused light. In the Sahel, this means that measurements can only be taken for 1 or 2 h after dawn or before sunset, whereas the radiometer can be used in bright sunlight during most of the working day.

The analysis of false color infrared aerial photographs to estimate millet dry matter and N stress has been evaluated by Gérard et al. (1997). The spatial resolution obtained from a low altitude photograph can be up to 1000 times higher than the radiometer sampling density but it has been shown in this study that photographic and radiometer data are highly correlated even over areas of only a few square meters. The advantages of the radiometer compared to aerial photographs is that no photographic processing is involved and it has very low operating costs once the initial investment in GPS equipment has been made. The labor costs involved in data acquisition by the radiometer or aerial photography from balloon or kite depend on the area surveyed. For a 1 ha field of millet, a radiometer survey takes approximately 2 h for one operator while for aerial photography, the preparation of the equipment, and the shooting session itself take between 1 to 2 h for a team of four persons. Another advantage of the radiometer is that it is relatively easy to process its georeferenced data in a geographic information system (GIS) compared to the different steps involved in the analysis of a photograph. Spectral integrity of data when comparing measurements made at different dates is also better for the radiometer (so long as care is taken to do measurements under similar lighting conditions) than for aerial photographs, which are affected by lighting conditions, the composition and sensitivity of the photographic emulsion, the protocols used by the processing laboratory, and scanner settings.

### CONCLUSIONS

The use of the GPS-data logger enabled the rapid acquisition and processing of large numbers of spatial measurements in a GIS. When averaged across an area



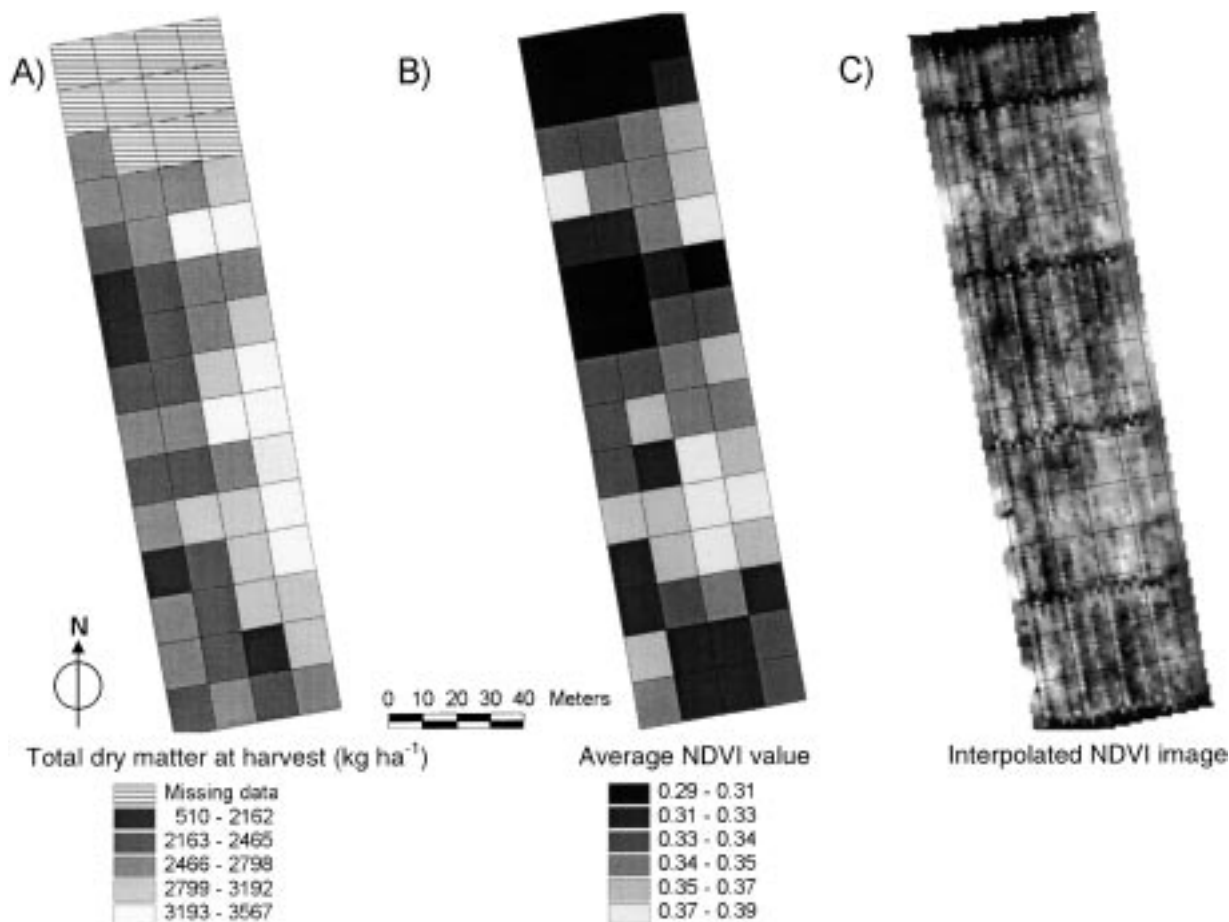

**Fig. 9.** Variability maps for destructive measurements of total dry matter at harvest compared to normalized difference vegetation index (NDVI) values taken 36 d before harvest on a millet field (trial 2) at Sadoré, Niger. Note that the darker areas in the NDVI image represent areas of low plant density. The four low vegetation E-W strips visible on map C correspond to the tracks of the linearly moved wheels of the irrigation system.

of a few square meters, NDVI measurements were found to be a good indicator of fractional millet cover and could be used to produce variability maps at the field level. The discrete measurement version of the radiometer permits the optimization of measurement interval according to plant population, plant growth stage, and sensor footprint. A processing algorithm should be developed to detect local maxima and minima for the estimation of individual isolated plants. By integrating discrete NDVI measurements or using the continuous measurement version of the radiometer, it was possible to estimate millet plant cover and total dry matter. The continuous measurement version also gave a good indication of plant growth variability at the field level but did not permit the detection of NDVI peaks corresponding to individual millet plants. Its use is particularly recommended for surveying large fields because the requirement for data logger memory per unit area is lower. The use of both versions of the equipment can be recommended for monitoring plant growth and treatment response in agronomic trials because they provide a tool for aggregating measurements at the plot level in a GIS which enables a rapid and comprehensive assessment of the dynamics of plant growth with high

spatial precision. A goal of future studies should be the optimization of the sample spacing (instrument 1) or the averaging distance (instrument 2) according to plant spacing and field heterogeneity. Although the main attraction of these instruments is their ability to give location specific data when linked to a GPS, the continuous measurement version (instrument 2) is a rugged and cheap instrument that enables the collection of useful data even when a GPS and associated automatic data logging equipment are unavailable.

The correlation between aggregated NDVI measurements and millet crop yield needs to be further investigated with various millet genotypes. Further testing on soils with different reflectance characteristics in the red and near-infrared wavelength is still required to assess whether soil specific NDVI-plant dry weight calibration curves are necessary rather than relying solely on the simplistic soil correction factor used in this study.

#### APPENDIX

Derivation of the formula (formula 2) to correct observed NDVI ( $NDVI_{obs}$ ) for the NDVI of soil ( $NDVI_{soil}$ ):

During the initial setting up of the radiometer, the sensors are held over a white sheet of paper. Under these conditions,

the amplified signals from the two diodes are equalized so that the observed NDVI is equal to zero, that is, the ratio

$$\frac{\text{Amplified response of sensor to red light}}{\text{Amplified response of sensor to NIR light}} = 1.0$$

This ratio, designated 'C', is related to NDVI by

$$C = \frac{1 - \text{NDVI}}{1 + \text{NDVI}}$$

hence

$$\text{NDVI} = \frac{1 - C}{1 + C}$$

Measurements of NDVI of partial plant cover can then be made provided that the background of soil or other nonplant material has the same NDVI as the original sheet of paper, that is, any observed changes in NDVI are due to the plant material and not to the background. If this is NOT the case then the observed NDVIs must be adjusted either by physically readjusting the radiometer over the new background or algebraically by restoring the value of C to 1.0 by multiplying by 1/C or  $\frac{1 + \text{NDVI}}{1 - \text{NDVI}}$ . Therefore, to remove the  $\text{NDVI}_{\text{soil}}$  from an

observed NDVI of plant material on the same soil ( $\text{NDVI}_{\text{obs}}$ ), where  $\text{NDVI}_{\text{obs}} = \frac{1 - C_{\text{obs}}}{1 + C_{\text{obs}}}$ , the value of  $C_{\text{obs}}$  must be multiplied by  $1/C_{\text{soil}}$  or  $\frac{1 + \text{NDVI}_{\text{soil}}}{1 - \text{NDVI}_{\text{soil}}}$ . But since  $C_{\text{obs}} = \frac{1 - \text{NDVI}_{\text{obs}}}{1 + \text{NDVI}_{\text{obs}}}$ , then the corrected NDVI

$$\text{NDVI}_{\text{corr}} = \frac{1 - \frac{(1 - \text{NDVI}_{\text{obs}})(1 + \text{NDVI}_{\text{soil}})}{(1 + \text{NDVI}_{\text{obs}})(1 - \text{NDVI}_{\text{soil}})}}{1 + \frac{(1 - \text{NDVI}_{\text{obs}})(1 + \text{NDVI}_{\text{soil}})}{(1 + \text{NDVI}_{\text{obs}})(1 - \text{NDVI}_{\text{soil}})}}$$

which simplifies to

$$\text{NDVI}_{\text{corr}} = \frac{\text{NDVI}_{\text{obs}} - \text{NDVI}_{\text{soil}}}{1 - (\text{NDVI}_{\text{obs}} \times \text{NDVI}_{\text{soil}})}$$

The numerical value of the correction (that is,  $\text{NDVI}_{\text{obs}} - \text{NDVI}_{\text{corr}}$ ) varies from  $\text{NDVI}_{\text{obs}}$  when  $\text{NDVI}_{\text{obs}} = \text{NDVI}_{\text{soil}}$  to zero when  $\text{NDVI}_{\text{obs}} = 1.0$ . This means that the formula is correct only if 100% plant cover gives a NDVI of 1.0. A more complex formula would be needed if actual values for the NDVI corresponding to 100% plant cover were available but computer simulations show that application of the simple formula would involve little error so long as  $\text{NDVI}_{\text{soil}} < 0.3$  and the NDVI for 100% plant cover  $> 0.8$ .

Note: It is possible to arrive at the same result without introducing 'C' values but the derivation is much less elegant.

## ACKNOWLEDGMENTS

The authors thank Dr. André Bationo and Dr. K. Anand Kumar for giving access to their experiments, Mr. Tahirou Saley and Mr. Mamane Bachir for their technical assistance during field work, the ICRISAT Sahelian Centre for infra-structural support, and the Deutsche Forschungsgemeinschaft (DFG) for funding within the SFB 308.

## REFERENCES

- Buerkert, A., P.R. Lawrence, J.H. Williams, and H. Marschner. 1995. Non-destructive measurements of biomass in millet, cowpea, groundnut, weeds and grass swards using reflectance, and their application for growth analysis. *Exp. Agric.* 31:1-11.
- Bausch, W.C. 1993. Soil background effects on reflectance-based crop coefficients for corn. *Remote Sens. Environ.* 46:213-222.
- Blackmer, T.M., J.S. Schepers, G.E. Varvel, and G.E. Meyer. 1996. Analysis of aerial photography for nitrogen stress within corn fields. *Agron. J.* 88:729-733.
- Carlson, T.N., and D.A. Ripley. 1997. On the relation between NDVI, fractional vegetation cover, and leaf area index. *Remote Sens. Environ.* 62:241-252.
- Colwell, J.E. 1974. Vegetation canopy reflectance. *Remote Sens. Environ.* 3:175-183.
- Fernandez S., D. Vidal, E. Simon, and L. Sole-Sugranes. 1994. Radiometric characteristics of *Triticum aestivum* cv. Astral under water and nitrogen stress. *Int. J. Remote Sens.* 1:1867-1884.
- Gérard, B., A. Buerkert, P. Hiernaux, and H. Marschner. 1997. Non-destructive measurement of plant growth and nitrogen status of pearl millet with low-altitude aerial photography. *Soil Sci. Plant Nutr.* 43:993-998.
- Hicks, S.K., and R.J. Lascano. 1995. Estimation of leaf area index for cotton canopies using the LI-COR LAI-2000 plant canopy analyzer. *Agron. J.* 87:458-464.
- Huete, A.R., R.D. Jackson, and D.F. Post. 1985. Spectral response of plant canopy with different soil backgrounds. *Remote Sens. Environ.* 17:37-53.
- Mahalakshmi, V., and F.R. Bidinger. 1986. Water deficit during panicle development in pearl millet: Yield compensation by tillers. *J. Agric. Sci., Camb.* 106:113-120.
- Nageswara Rao, R.C., J.H. Williams, V.M. Rao, and K.D.R. Wadia. 1991. A hand-held red-infrared radiometer for measuring irradiance interception by crop canopies. *Field Crops Res.* 29:353-360.
- Neale, C.M.U., W.C. Bausch, and D.F. Heermann. 1989. Development of reflectance-based crop coefficients for corn. *Trans. ASAE* 32: 1891-1899.
- Penulas, J., J.A. Gamon, A.L. Fredeen, J. Merino, and C.B. Field. 1994. Reflectance indices associated with physiological changes in nitrogen- and water-limited sunflower leaves. *Remote Sens. Environ.* 48:135-146.
- Tucker, C.J., and P.J. Sellers. 1986. Satellite remote sensing of primary production. *Int. J. Remote Sens.* 7:1395-1416.
- Welles, J.M., and J.M. Norman. 1991. Instrument for indirect measurements of canopy architecture. *Agron. J.* 83:818-825.
- West, L.T., L.P. Wilding, J.K. Landeck, and F.G. Calhoun. 1984. Soil survey of ICRISAT Sahelian Center, Niger, West Africa. Texas A&M University/TropSoils, College Station, TX.
- Zhu, Z., and D.L. Evans. 1992. Mapping midsouth forest distribution. *J. For.* 90:27-30.