

# Mediating between Concepts and Grammar

*Edited by*

Holden Härtl

Heike Tappe

Mouton de Gruyter  
Berlin · New York

Mouton de Gruyter (formerly Mouton, The Hague)  
is a Division of Walter de Gruyter GmbH & Co. KG, Berlin.

⊗ Printed on acid-free paper which falls within the guidelines  
of the ANSI to ensure permanence and durability.

ISBN 3-11-017902-4

*Bibliographic information published by Die Deutsche Bibliothek*

Die Deutsche Bibliothek lists this publication in the Deutsche Nationalbibliografie;  
detailed bibliographic data is available in the Internet at <<http://dnb.ddb.de>>.

© Copyright 2003 by Walter de Gruyter GmbH & Co. KG, D-10785 Berlin  
All rights reserved, including those of translation into foreign languages. No part of this  
book may be reproduced or transmitted in any form or by any means, electronic or mechan-  
ical, including photocopy, recording or any information storage and retrieval system, with-  
out permission in writing from the publisher.  
Cover design: Christopher Schneider, Berlin.  
Printed in Germany.

# Mediating between concepts and language – Processing structures\*

*Heike Tappe and Holden Härtl*

## 1. Modules and interfaces

One of the main functions of language is to abstract over complex non-verbal message structures. The language system generates highly compact linguistic material which, however, must still enable the recipient of the corresponding linear grammatical sequence to fully infer the intended message. To guarantee this a device is required which links concepts and grammar in a systematic fashion by negotiating the requirements of both the generalized linguistic structures and the underlying conceptual complexes. Typically, this mediating function is instantiated by an *interface*. Any interface device has to satisfy procedural requirements because linguistic structure building must accommodate the fact that different types of information are available at different points in time.

Regarding aspects of design, an interface is a virtual or an actual surface forming a common boundary between independent functional units. It can be defined as a point of information transition and communication. In a technical sense, an interface definition encompasses rules for information transfer and calls for a characterization of the kind of data that can be handed over from one unit to the other. This also entails the specification of structure-sensitive operations over those representations that are the output structures of one functional component and serve at the same time as input structures for the subsequent component. The diction *independent functional unit* is akin to the term *module*, in that both notions imply a more or less autonomous and specialized computational system to solve a very restricted class of problems and uses information – which are its proprietary – to solve them (cf. Fodor 1998).

In cognitive science it is widely held, that at least some human cognitive mechanisms are organized in modules.<sup>1</sup> Fodor (1983) defines them as cognitive systems characterized by nine criteria, some of which concern module-internal information processing with implications for how the interface between such modules is to be defined. The most prominent of these criteria are *informational encapsulation* and *domain specificity*, meaning that; first, the inner workings of a module cannot be directly influenced from the outside. Second, that each module computes information of one distinct type, which, however, has to be of tremendous significance to the species. Further characteristic features are the following: *Unconsciousness*, i.e. module-internal processing is opaque to introspection. *Speed* and *shallow output*, which characterize modules as extremely fast cognitive sub-systems producing a particular output, albeit without providing information about the mediating stages preceding it. Additionally, modules are processing pre-determined inputs, which in turn result in pre-determined outputs devoid any contextual influence (*obligatory firing*).<sup>2</sup> Since it was advanced Fodor's notion of modularity has stimulated a vivid controversy and an enormous body of research. In particular the idea of information encapsulation has become fundamental to computer science. Many standard technologies of programming are based on this feature. Modularity also plays a key role in artificial intelligence and computational linguistics: Today even systems within sub-symbolic intelligence such as neural network systems depart from their traditional homogenous architectures and use somewhat modular approaches especially so to natural language processing (cf. McShane and Zacharski 2001). While it is thus largely agreed upon that the human mind/brain is organized into domain specific components (except in rigorous connectionist approaches), it can be witnessed that the current interpretation of the term *module* varies immensely depending on the underlying general framework (cognitivist, neuro-psychological, evolutionary connectionist, etc.). Generally, it seems that Fodor's modularity assumptions are only partly shared in existing models of the human mind/brain, i.e. the proposed modules are not usually held to possess all nine Fodorian criteria.

The related question whether the human language system is carved up into functional units and – more strongly – whether these or some of these are full-fledged modules in Fodor's sense has been a hotly debated question in linguistics, philosophy and psychology over the last two decades. Because of space limitation we cannot reiterate this intricate discussion (but cf. e.g. Karmiloff-Smith 1992, Marshall 1984, Frazier 1987a, Smolensky 1988 and Müller 1996 for varying viewpoints on modularity). Generally, this thematic complex is closely connected with a persistent delimitation effort in linguistics. It is broadly held indispensable for both the definition of the discipline and for scientific distinctness to accomplish an analysis of language as a formal system. This endeavor dating back to de Saussure (1916) has had its reflex in syntactic and semantic theory alike. Consequently, the predominant position subsumes under the term *syntax* language specific competencies of how symbols of some language may be combined independent of meaning, of other cognitive computations, and of socio-cultural requirements (cf. e.g. Chomsky 1986). Likewise, formal semantics strives to explicitly identify those aspects of *meaning* that are genuinely linguistic, i.e. abstract-able from general world knowledge, and at the same time persistent in all syntactic alternation contexts (cf. Cresswell 1978, Montague 1970, for an overview Bäuerle 1985). In the consequence formal approaches in linguistics have to date been primarily engaged in consistently explicating language internal structures.

Starting in the 70ies, research in cognitive science, anthropology, and psychology inspired approaches that deny the autonomy of syntax – and of linguistic subsystems in general – in relation to conceptual structure. They interpret grammatical phenomena in terms of more general cognitive principles with applications outside language. These have been subsumed under the terms of *cognitive grammar* and *functional grammar* (e.g. Bates and MacWhinney 1984, Deane 1992, Lakoff 1991, Langacker 1987, 1990, 1991, Gärdenfors 2000, and Tomasello 2000a, 2000b). Without the assumption of functional units that are engaged in some kind of division of labor, the notion of a restrictive mapping device becomes superfluous as the different parts of the language faculty are concep-

tualized as being highly interactive and having access to basically the same information and knowledge sources.

The epistemological question, whether a formalist or a functionalist conception is preferable, gains in relevance when we take into consideration language processing. The overarching endeavor to develop models for language production and comprehension systems calls for a specification the relevant sub-components and carries in itself the need to describe and to explain the interaction of informational sources. This objective is characteristic for approaches that attempt to preserve some of theoretically sound and the empirically founded assumptions of theoretical linguistics and to incorporate them into a language processing framework (cf. e.g. Levelt 1989, Bierwisch and Schreuder 1992). Language production and language comprehension processes are based on representations, on which they operate. The computation of the linguistic meaning and thus the communication of information are impossible without an accessibility of both general and linguistic knowledge. From this follows the prime question: Which kinds of information interact in what fashion and at what points in time during language processing? What we are addressing here is the *processing criterion*, i.e. are the representations a given linguistic theory proposes computable by a language processing system (Marcus 1982, Fodor 1983, Frazier 1987b, Frazier, Clifton and Randall 1983, Berwick and Weinberg 1983). This means that if we assume that grammars are theories of abstract linguistic competence (e.g., Chomsky 1986), we have to ask whether they may or may not provide an appropriate framework for understanding the mental processing of language (Stillings et al. 1998: 435).

Unfortunately, the discussion between different schools in language research remains – as Newmeyer (1998) points out – to date largely unsatisfactory. They tend to avoid direct confrontation and thus they generally are unaware of the compatibility of their results. For the most part this observation also characterizes the interdisciplinary communication on matters of modularity and in the consequence on the structures and processes, which play a role at the interfaces in question. While the understanding of how the linguistic

and the non-linguistic system interact, constitutes one of the most interesting and central questions in language research, both an intra-disciplinary and interdisciplinary convergence seems to be a long way off. The respective definitions of the interface between grammar and concepts – as well as its allocated character and scope – vary substantially subject to the vigorousness of the underlying modularity assumption. In the well-established Levelt model (1989) – that has provided the reference architecture for the majority of research in language production – the most intensively discussed interface representation is the so-called *preverbal message*. In the rigorous interpretation it links non-linguistic and linguistic structures. However, the question whether the preverbal message itself is to be interpreted as purely non-linguistic is to date still hotly debated. And, in the consequence there exist profound controversial assumptions about its general character and content. From this follows that the impact of features in the preverbal message on the subsequent representations remains under discussion especially regarding the realization of this information by the sub-components of the linguistic system. This concerns e.g., the question whether the linguistic realization of a preverbal message such as the word order of the utterance is determined by the order in which concepts are selected, or, is the outcome of purely grammatical operations.

In order to enhance both intra- and interdisciplinary exchange about these issues, the current volume brings together researchers both from theoretical linguistics and from language processing as well as researchers from adjacent disciplines such as computer-science and psychology. While all contributors acknowledge some division of labor between lexical(-semantic), morphological, syntactic, and phonological structuring, it is not surprising that they do not define the respective sub-components and their substance in the same way. Especially the term *semantics* receives different interpretations as notions relating to meaning have long and often controversial histories within the disciplines that contribute to this volume, which are related to foundational and methodological differences. As a consequence, the current volume comprises contributions that a traditional perspective on the interface function in question would

not integrate. Although findings from language comprehension studies are also discussed, the main body of contributions center around aspects of language production. In this field available definitions of the concrete interaction between the conceptual/semantic and the grammatical level are to date still of a tentative nature. The dispute in the book will shed light on this issue by exploring the several stages of processing ranging from the conceptual knowledge, its recruitment, and preverbal preparation for linguistic computation, to finally its grammatical realization.

In the following paragraphs we give an overview of prominent – and in the interest of space selected – interface conceptions from the perspectives of both the grammatical and the conceptual systems and relate those to questions of language processing. Subsequently, we introduce the contributions to this volume, which demonstrate various parallels and common attitudes in spite of differences in focus, research background, and modeling.

### *1.1. Linking to syntax*

The assumption that a linguistic capacity of the human mind/brain enables speakers to competently master their native language is tightly intertwined with the influential work of Fodor (1983) and Chomsky (1986). Both assert the existence of a specialized language faculty, which is conceived as a mental organ<sup>3</sup> and as being internally organized into several functional subsystems. Especially Chomsky's arguments in favor for a linguistic module are based on phenomena which are hard to explain on other but syntax-internal grounds.<sup>4</sup> Further compelling evidence for genuine linguistic syntactic principles are found in language acquisition (e.g. Meisel 1990, Stromswold 1992, Tappe 1999) and Creole language data (e.g. Bickerton 1990).<sup>5</sup> The division of the cognitive system into functional sub-components implies the existence of specific principles organizing the representations within each component. More importantly in the present context, it follows from this conception that mapping mechanisms between the components be specified.



It is generally acknowledged that for a successful coupling between (lexical) semantics and syntax predicates have to provide such lexical information as the number of arguments and the syntactic structure into which these arguments are to be integrated. In spite of this broad consensus, the proposals about how such an interrelation between syntactic and semantic structures may be realized vary substantially.

Recent syntactic theories characterize syntactic operations by minimalist principles, which are subject to directives of economy and explicitness. In the minimalist framework (cf. e.g. Chomsky 1995) lexical items enter the syntactic building process fully equipped with their grammatically relevant features including categorial, semantic argument structure, and thematic features. The relevant operation *select* maps lexical items from a set of elements activated from the lexicon onto the computational process. This process makes use of two basic mechanisms, i.e. *merge* and *move*. Furthermore, *procrastinate* regulates that syntactic movement has to take place as late as possible in the derivation, if there is a choice, which differs from language to language thus creating language-specific word order variations. The underlying idea is that covert movement is 'less costly', because it does not have to pied-pipe phonological features (cf. e.g. Chomsky 1995, Wilder and Čavar 1994). In this fashion the syntactic component produces structures that are compatible and legible to the linguistic levels adjoining the syntactic level and also to the levels adjacent to the linguistic system itself. The language faculty has to meet specific interface conditions to allow for interaction with the adjoining nonlinguistic components. This requirement has led Chomsky (2000) to the conclusion that "language is an optional solution to legibility conditions". These legibility conditions have to involve principles of how syntactic material is to be mapped onto phonological representations of the articulatory-perceptual system on the one hand, and the semantic representations of the conceptual-intentional system on the other.

Developing a somewhat different approach to modeling the lexicon-syntax interface within the feature-checking framework of the minimalist program (Chomsky 1995), van Hout (1996) proposes a

*C*hecking *E*vent-*S*emantic *S*tructure model (CHESS). She assumes that the event structure of a predicate must be syntactically identified (cf. Grimshaw 1990; Grimshaw and Vikner 1993) and defines the mapping relation in terms of checking event-semantic features in functional configurations. There are two structural argument positions: the specifier positions of AgrS and AgrO. An argument in either of these positions identifies an event or subevent by referring to an event participant that is involved in that (sub)event. Telic event type features must be checked in AgrOP. Van Hout argues that the CHESS model accounts for the event-semantic mapping generalizations in a natural way, explaining the phenomenon of lexical-syntactic flexibility as a derivative of event-type shifting.

These current developments within syntactic theory are compatible with semantically oriented approaches that assume specific linking mechanisms operational between semantic and syntactic structure. Here it is held that specific configurational constellations in the semantic representation determine the syntactic realization of a language. In Bierwisch (1986) and Wunderlich (1997) the mapping of arguments onto syntactic structure is organized through the embedding of the arguments in the *semantic form representation*, i.e. a predicate-argument structure. Jackendoff (1990) advances a similar approach with the difference that he assumes *correspondence rules* to negotiate between syntactic and semantic-conceptual structure. Moreover, he also claims that lexical syntactic representation of a predicate can always be reduced to its lexical semantic representation. In the consequence he treats the semantic and syntactic information of the lexicon as part of *conceptual structure* whereby arguments correspond to ontological categories of conceptual structure.

This latter claim differentiates Jackendoff's account considerably from most *linking theories*. Based on the observation that some pairs of predicates like, e.g. *ask* and *inquire* have different syntactic subcategorizations albeit their semantics are identical, Grimshaw (1979) proposes that predicates select both *syntactic objects* (nouns phrases, sentences and *semantic objects* (propositions, questions, exclamations) with no correlation between the two. The linking between the

two distinct types of information is handled by *thematic hierarchies* where semantic argument features like AGENT, BENEFACTIVE or THEME organize the order of arguments to be realized in syntax (cf. Baker 1997, Grimshaw 1990, Jackendoff 1972 among many others). AGENTS, for example, surface in a hierarchically higher position (as subject) than THEMES (as direct object in transitive verb complexes).

The very nature of argument structure is less than clear.<sup>6</sup> ‘Linking theoreticians’ assume that argument structure not only contains thematic information but that it is also closely tied up with event structure, which contains aspectual information (cf. Grimshaw 1990).<sup>7</sup> Tenny (1992, 1994) assumes that only aspectually relevant information is mapped onto syntax (*Aspectual Interface Hypothesis*). In the other extreme, researchers like Rappaport and Levin (1988) encode no more than syntactically relevant information into argument structure, which thus does not contain any thematic role specifications. As becomes evident from this discussion, most of the various exemplary conceptions of the mapping between syntax and semantics are joined by the consistent assumption that there is an independent level, where lexical properties such as predicate-argument structures are calculated. However, the question of what kind of information influences and/or is to be integrated into this structure during language processing has not yet received a widely accepted mutual answer. This is partly due to the fact that syntactic theories tend to center around the outcome of the computation rather than a real time piecemeal construction of syntactic strings. In this context, the question of how information is weighted such that the salience of the constituents has its reflexes in an incremental syntactic realization gains central importance.

## *1.2. Semantics*

As was already hinted at in the first paragraph, formal model-theoretic approaches towards meaning assume a modular organization of linguistic processes: A morpho-syntactic component generating overt linguistic sequences and a semantic component, which relates the grammatical material to extra-linguistic structures. General-

ly the focus of investigation the pairing of syntactic categories and semantic types and the subsequent model-theoretical interpretation of the analyses (e.g. in the framework of *categorial grammar*, Ajdukiewicz 1935). The prime target is to specify how linguistic expressions fit the world. Therefore investigations center, first, around *referring expressions*, (syntactically encoded in noun phrases) and, second, around *truth-conditions* of propositions, including the exploration of which inferences follow from a linguistic expression (cf. e.g. Lewis 1972, Tarsky 1977). Under this perspective the linking between syntax and semantics the need to further explicate the linking between syntax and semantics does not arise because here syntactic structures are considered categorical complexes, whose interpretation is derived compositionally from either the syntactic parts or their fixed meaning, respectively.

Syntactic constellations are deemed relevant only if the modification of a linguistic string results in different *entailments* such that the truth conditions underlying the expression in question are altered. Correlations between certain linguistic expressions are taken to be of a logical rather than a grammatical nature (cf. Montague 1973, Partee 1975, Dowty 1979). Grammatically different but logically identical sentences inducing parallel entailments like the three examples in (1) are generally treated in a homogenous fashion. The differences between them are ascribed to information structure and focus packaging routines.

- |     |  |  |                         |
|-----|--|--|-------------------------|
| (1) | <ul style="list-style-type: none"> <li>a. <i>Somebody killed the fly.</i></li> <li>b. <i>The fly was killed.</i></li> <li>c. <i>The fly, somebody killed.</i></li> </ul> | $\left. \begin{array}{l}   \\   \\   \end{array} \right\} \Rightarrow$ | Somebody did something. |
|-----|--|--|-------------------------|

Decompositional approaches strive to grasp further entailments that cannot be explicitly derived from overt form, but need to be inferred from inherent meaning features. To this aim they employ the concept of *basic meaning components* (cf. Katz and Fodor 1963, McCawley 1971 and many others). Under the assumption that complex meanings are built up from smaller units such as CAUSE or NOT ALIVE,

more specific entailments can be logically derived from the sentences in (1), cf. examples in (2).

- |     |    |                                  |  |
|-----|----|----------------------------------|--|
| (2) | a. | <i>Somebody killed the fly.</i>  | = CAUSE[somebody,[BECOME[¬ALIVE fly]]] |
|     | b. | <i>The fly was killed.</i>       |  |
|     | c. | <i>The fly, somebody killed.</i> | ⇒ Somebody did something               |
|     |    |                                  | ⇒ Somebody caused something to happen  |
|     |    |                                  | ⇒ Something became not alive           |

Although purely logically oriented, decompositional approaches can thus capture implicit entailments, they cannot address the issue of contextually driven *truth evaluations*. Under the assumption that – in order to adequately convey a message structure – such information structural values determining an expression are to be defined as reflexes of the speaker's intention, a broader notion of what is meant by the term *propositional content* is needed. Consequently, the truth conditions underlying the example in (2c) have to imply that this sentence can have been uttered only in a specific contextual (i.e. a contrastive) situation: The respective discourse set needs to contain at least one more object such that the contrastive function of the expression can be evaluated as true.

A further shortcoming of purely logically oriented semantic theories is that they have to define truth conditions that must hold in every possible situation the corresponding expression occurs in. For example, a semantic analysis for short passives – cf. examples in (3) – has to explain the fact that passives can be accompanied by purpose clauses, which imply that there is an implicit agent denoted in the matrix clause. This leads to the conclusion that the truth conditions underlying passives have to signify an (existentially bound) individual (cf. Brody and Manzini 1988, Roeper 1987, Koenig and Maurer 1999, for discussion).

- (3) a. *The letter was written in order to impress the duchess.*  
 b. *The letter was written but it never reached its addressee.*

In (3a) the implicit agent of the purpose clause (the one who impresses) and the demoted entity in the matrix clause (the one who wrote the letter) are co-referential. Although this can surely be taken as evidence for the conceptual existence of an implicit agent in short passives, nothing prevents us from rejecting this assumption in cases like (3b) where no purpose clause is added. However, the latter hypothesis can merely be upheld if we assume a level of language processing where only those pieces of information are provided which are relevant for a successful realization of the communicative act. Consequently, for a message like (3b) an implicit agent – as it does not gain any referential salience – might not be present in the semantic-conceptual structure underlying the message. Only in cases where a conceptual activation of a corresponding entity becomes relevant (as in (3a)) this knowledge has to be retrieved. Yet, in order to cover cases where contextual constellations indeed require the conceptualization of an entity, truth-theoretic analyses over-generate and represent both sentences alike. Obviously, this problem concerns the notion of *conceptual activeness* and here empirical and procedural evidence may provide a solution by indicating the concrete conceptual constellations holding during actual language processing in real time. Against this background, it is apparent that experimental results can not only help to reveal stages of language processing and to define an adequate processing model, but also to indicate how linguistic expressions be analyzed and to determine corresponding representations.

Generally, semantic theories are, of course, not oblivious of the importance of context- and situation-dependent aspects of meaning construction, as is emphasized, e.g. in *situation semantics* (cf. Barwise and Perry 1983, among others). Here, sentence meanings are built up compositionally as functions from reference situations to described situations. Thereby contextual factors reflecting specific speech situations are incorporated into the study of meaning such that expressions like *I*, *this*, and *yesterday* in *I saw this plate on the table yesterday* are evaluated against the context of the actual speech event. In this way, adequate means to determine corresponding truth-values are provided. In a similar fashion, Kaplan (1977) distin-

guishes between fixed context-independent *character* of an expression and its *content evaluation*. The latter concept accounts for the fact that the meaning of linguistic units is adapted to contextual requirements and acknowledges that the interpretation of indexical expressions like (demonstrative) pronouns is dependent on time.

In contrast to the model-theoretic approaches sketched above, semantic theories that include grammatical aspects into the analysis of linguistic expressions are enabled to explain entailment relations between sentences that are based on lexical and morpho-syntactic constellations. Consider the following examples:

- |     |    |                                   |  |                                |
|-----|----|-----------------------------------|--|--------------------------------|
| (4) | a. | <i>John broke the mirror.</i>     |  | <i>The mirror broke.</i>       |
|     | b. | <i>John destroyed the mirror.</i> |  | * <i>The mirror destroyed.</i> |

The difference between *destroy* and *break* can be put down to inherent features of the respective lexical entries.<sup>8</sup> Levin and Rappaport Hovav (1995), for example, argue that only those verbs detransitivize which can express a change of state coming about without the intervention of a volitional agent, i.e. which can instead denote an effect of a natural force. In this sense, lexical semantics seeks to define predictable relations between semantic features and overt grammatical behavior, which, at the same time, allows to predict possible semantic relations between sentences such that a transitive verbal complex entails the corresponding intransitive one and vice versa.

Likewise, decompositional lexico-semantic approaches control the mapping of grammatically relevant aspects of meaning structures onto linguistic form by encoding grammatically visible differences in meaning by way of decompositional representations, which are linked to morpho-syntactic representations. As we pointed out in paragraph 1.1, for now there is still no agreement on the question whether meaning aspects visible in grammar are to be defined as a subset of the conceptual, non-linguistic level of language processing or rather as part of the linguistic system. The former assumption implies that conceptual structures are directly linked to syntactic structure – a view that is employed by conceptual semanticists like

Jackendoff (cf. Jackendoff 1992, 1997). Here, conceptual structures that constitute the non-linguistic message have to be compatible with both the linguistic system with its independent language-specific requirements on the one hand, and the conceptual knowledge base organizing information from the several sensory and memory systems on the other hand. In contrast, a more modular conception of the encoding of grammatically relevant aspects of meaning is incorporated in theories that assume a separate, lexico-semantic level, which is organized by strictly linguistic principles. This grammatically determined level – the *semantic form* – of meaning representation is distinguished from a non-verbal, conceptual level comprising propositional information of a message level by semanticists like Bierwisch (1983), Dölling (1998), Ehrich (1992), Härtl (2001), Lang (1994), Olsen (1998), and Wunderlich (1997). Similar distinctions have been formulated in Mohanan and Wee (1999), who differentiate a semantic structure from a conceptual structure, or Grimshaw (1993) who distinguishes between the semantic content of an expression and its semantic structure. Similarly, the logical form level (LF) of syntactically reflected meaning aspects such as the scope of quantifiers or of negations in the Government & Binding program and its successors (Chomsky 1981, 1993 and many others) can be considered a reflex of the need for a linguistically determined level of semantic information. These rules generate semantically adapted structures, which then are mapped onto representations of the conceptual-intentional system of the conceptual knowledge base interfacing the several conceptual subsystems that organize the world-knowledge of an individual.<sup>9</sup> While these conceptions are in themselves quite elaborated, they are still largely oriented towards the linguistic representations as outcome of processing stages, while the processing aspects themselves are largely ignored. In language production research, however, it is of prime importance to clarify how conceptual structures might influence the construction of linguistic representations and thus also the variability of semantic and syntactic structures.



### 1.3. Conceptualization

As has become apparent in paragraph 1.2 cognitively oriented semantic theories are primarily concerned with the question of how semantic representations systematically interface non-linguistic and syntactic representations. More broadly considered this is a common goal in the interdisciplinary research aiming at understanding the language faculty and its interaction with other cognitive capacities. In this context the basic ontological categories, i.e. *objects* and *events*, and how their respective conceptualization relates to verbalization and comprehension are of prime importance. Growing evidence from psychological and neurological research indicates that objects and events cannot only be differentiated on philosophical and theoretical grounds, but that the neural processing of these two basic entity types engages discriminable sub-parts of semantic memory (cf. e.g. Caramazza 1997).

Being able to talk about an object or to decode a specific object reference has as its prerequisite *object recognition*. This complex mental operation involves two more basic processes concerning *object constancy* and *object categorization*. The first one relates to stability of object recognition independent of spatial transformations, i.e. regardless of a given object's orientation, size and position.<sup>10</sup> The second one—*object categorization*— involves the ability to perceive and categorize different objects as members of the same category. In order to be able to tackle the second task, perceptual or conceptual equivalences among the objects within a given class have to be detected (cf. e.g. Anderson 1991, Bloom 1998, Medin 1989).

For the contributions to the current volume these two cognitive processes are less important than the fact that humans generally experience objects in various locations and in many different spatial arrangements. Consequently the spatial configurations in which objects occur and the spatial relations that hold between different objects become essential for linguistic encoding of situations. In verbalization and in comprehension spatial relations between objects, which may freely employ the multidimensionality of space, have to be linked to a linear string of linguistic expressions. Verbal

expressions typically contain projective expressions (e.g. *left, right*) that are dependent on a specific perspective reflecting a view point on the described situation. Perspectives are linguistically encoded by utilizing *reference systems*, i.e. systematically structured fields of linguistic expressions. Spatial reference systems are usually subdivided into two major classes. *Egocentric* reference systems are those in which relations between objects are specified in relation to body coordinates of an observer (most prominently body-axes or retinal coordinates). In environmental reference systems, on the other hand, locations are characterized via objects other than the speaker; examples are *absolute* reference frames employing cardinal directions (*North, South, East, West*), or, reference systems making use of prominent landmarks (e.g. '*hillwards*') (cf. Levinson 1996). As has been pointed out in the literature, the employment of spatial perspectives on a given situation is influenced by various parameters and often is not maintained throughout a description (cf. e.g. Taylor and Tversky 1996, Tappe 2000).

Object conceptualization also plays an essential role in event conceptualizations, as in events entities figure as event participants. Fundamental features of event structure must be accessed to assure language processing, which e.g. determine during comprehension which syntactic structure is projected. Depending on whether or not the speaker/hearer identifies an initiator of the event, the verb class will vary. A verb like, e.g. *push*, requires an initiator (which means at the same time that it is always transitive), whereas *break* may or may not encode an event with an initiator (i.e. may also be intransitive). Another feature concerns whether there is an endpoint of the event (telicity). Telic events must have an underlying direct object (cf. O'Brian, Folli, Harley and Bever, in prep.).

In the larger context of event conceptualization the influence of conceptual features like—most prominently—animateness on linguistic processing and on linguistic encoding are investigated. A feature like [+animate] is reflected e.g. in sortal preferences for argument roles. An animated entity is preferably identified as the initiator of an event and therefore assigned the agent role.

The assignment of thematic roles is part of the *conceptual structuring of situations*, which is a complex process encompassing a variety of conceptual operations. As our environment consists of a continuous flow of activity, the perceptual and conceptual segmentation this continuation into meaningful units is a precondition to linguistic encoding. This insight leads to a modification of Level's *principle of natural order*, which assumes a strict correspondence of chronological order and ordering of events.

What counts as natural ordering is different for different domains of discourse, and there is no general definition. Still, for certain important cases the notion is obvious. For event structures, the natural order is the chronological order of events (Levelt 1989: 138).

That this assumption is not tenable in a strict sense has been demonstrated in a variety of empirical investigations suggesting that, as Zacks puts it, "events arise in the perception of observers" (Zacks 1997). Thus, for conceptualizing of event structures some additional processes like *segmentation*, *structuring*, and *selection* have to be applied prior to linearization, which transform a continuous stream of experiences into a highly structured, often non-sequential event structures.<sup>11</sup>

Hierarchically organized event types are sometimes held to be stored in special sub part of the conceptual knowledge base, namely *semantic memory* (cf. Kintsch 1980). Semantic memory comprises an individual's ontological knowledge about the world at large in the format of rather abstract types.<sup>12</sup> The adjective *semantic* is ambiguous in the given context. In psychological literature a distinction between general conceptual ontological knowledge and genuine linguistic semantic knowledge is often either neglected, or, ignored. In some linguistic approaches, however, semantic and conceptual knowledge is systematically differentiated (cf. Lang, 1994 for extensive arguments in favor for this distinction).

#### *1.4. Interface in action*

In the previous sections we have provided an overview of prominent approaches to the interfacing of conceptual and linguistic representations. We have shown that from both sub-disciplines the linking between syntactic and semantic structures is either approached via intermediate representations such as argument structure, or taken as more or less given; e.g. in approaches that advocate quite a direct coupling between the two as in model-theoretical theories. We have pointed out persistent problems as how to model the different interface representations or linking mechanisms and some limitations of the respective approaches.

In the adjacent disciplines psychology and computational linguistics the problem also exists but in a somewhat different fashion. In both disciplines the processing aspect has been in greater focus as they do not generally treat language as a formal system in its own right. Either the overall research interest does not encompass this aspect – as in psychology for the most part – or, is back-grounded in the interest of building running systems.

In psychology the interfacing between different components of the language system is for the most part regarded from the perspectives of the three areas of psycholinguistic inquiry, that is *acquisition*, *comprehension*, and *production*. With reference to the latter two areas the main body of research focuses on language comprehension, since it is of prime importance to psychological researchers to make empirical data controllable and subject to experimental methods. Language production research is judged less manageable in these respects, especially concerning the production of longer strings of language, i.e. whole utterances and texts, because it is almost impossible to define dependent variables in these cases. Either the verbalization situation has to be highly restricted,<sup>13</sup> which then leaves speakers no choices in how to communicate the contents in question (and renders the whole endeavor pointless), or, the language data become too variant to pin down the more fine grained aspects of conceptualization and formulation.<sup>14</sup> Thus, psycholinguistic language production research mainly concentrates on impaired language pro-

duction (e.g. in aphasics), analyses of slips of the tongue and speech pauses, and lexical access studies. Especially in the latter field, intricate experimental paradigms have been developed to tease apart stages during which different features of a target word become accessible: A first stage of a *preverbal conceptual representation*. A second stage, during which an abstract representation of semantic and syntactic information is retrieved (i.e. *lemma selection*, *ibid*). And, a third stage, which eventually involves activation of the word's phonological representation (or *lexeme activation*, *ibid*), that will initiate articulatory encoding (cf. e.g. Jescheniak and Levelt 1994). As becomes apparent the interface problem is thus tackled in the transition from the conceptual component to the formulation component, as syntactic and semantic features of the target word are activated in parallel. The utterance formulation is conceived of as being driven via the selected lexical entries. However, the very nature of the conceptual representation is usually not addressed as in lexical access studies the probes for lemma and lexeme activation are either phonetically or graphically presented word or pictures. Thus, questions of choice of open class words, collocations, connotations, and sub-lexical relations and the like are not addressed.

This is akin to the common practice in the computer science, where *lexicalization* (or *lexical choice*) has also become the focal domain for a variety of sub-problems associated with the transition from conceptual (*what-to-say*) to lexical representation and formulation (*how-to-say*) levels (cf. Busemann 1993). Here, too, correspondences between conceptual and lexical entities deviating from the simple one-to-one pattern are not frequently encountered. In fact, very few existing NLG systems make a distinction between conceptual and semantic representations in any explicit way. Typically, they strive to reliably express their input from a well defined and limited domain – and succeed in doing so. In parallel, the syntax-semantics interface has been shifted into the lexicon: Most theories adhere to a compositional semantic conception, meaning in this context the construction of utterance meaning (and in the consequence utterance structure) from the meaning of constituents and phrases. The role of the other components has been considerable decreased in the conse-

quence and syntax is often reduced to one or two general principles. Information concerning the categorical identity and combinatorial constraints are projected from individual lexical entries. *Lexical-Functional Grammar* (LFG, Kaplan and Bresnan 1982), *Generalized Phrase Structure Grammar* (GPSG, Gazdar et al. 1985), *Head Driven Phrase Structure Grammar* (HPSG, Pollard and Sag 1987) and *Unification Categorial Grammar* (UCG, Zeevat et al. 1987) are prominent examples for such monostratal and lexical theories of grammar.<sup>15</sup>

In addition to being restricted to limited domains, existing NLG systems encounter persistent problems in at least three fields: In the appropriate tackling of *synonyms* and *near-synonyms*, in *machine translation* and in *artificial life applications*. These have in common the fact that a mere one-to-one mapping between the conceptual level and the linguistic levels does not yield appropriate results.

The solution to these problems is for the most part sought in modification of the system-architectures. The standard versions of NLG systems today are modular, relying on a strictly *sequential architecture* and a one-way information flow. Sequentiality and modularity yield stability, but they also result in rigidity of the system. The antipode to this conception is an *integrated architecture*, in which knowledge at all levels acts together. Interactive architectures are extremely flexible, albeit prone to system breakdown. Between these two extremes, we find architectures that

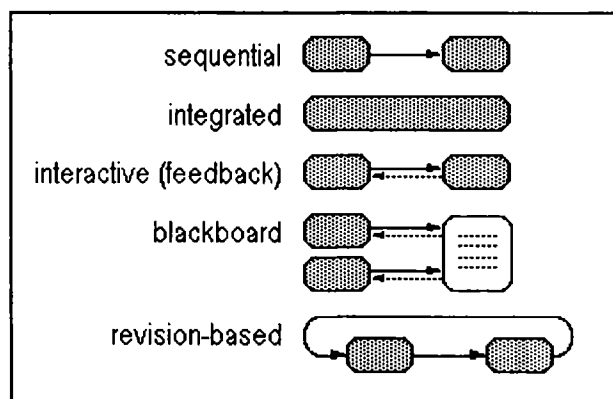

Figure 1. Schemes for control of information flow (ibid)

allow for various kinds of interaction between the modules. *Interactive architectures* allow for feedback processes between modules, whereas in *blackboard architectures* every module has access to common information that is shared between modules and laid down in a mutual data structure. *Revision based architectures* allow for a limited range of feedback via monitoring components. (For extended description of the architecture types viz. DeSmedt, Horacek and Zock 1996).

Apart from these conceptions, there is a growing endeavor to build *hybrid models* that combine advantages of different model types. Most prominently in the revised version of Levelt's model combines a modular architecture with interactive (connectionist) substructures – the latter are to be found within the formulator. More concretely the lemma-model is implemented within a spreading activation framework (WEAVER++, see Levelt, Roelofs and Meyer 1999).

In sum, the overview presented in this introduction shows that the processing problem is tightly intertwined with, first, the kinds of structures and processes we assume at the different stages of processing and the way we model their interaction – especially so at the transition from conceptual/semantic to syntactic representations. And, second, with the underlying modularity assumption, i.e. the proposed architecture of the language faculty, which also has a strong impact on the respective interface conceptions. The contributions in this book address these issues from various viewpoints and theoretical backgrounds. Either they take on a model-oriented perspective, or, concentrate on a specific phenomenon. One phenomenon that has currently received growing interest in the disciplines involved is the coupling between conceptualizations of events and their grammatical realizations. This issue is notoriously complex (viz. paragraphs 1.1 and 1.2) as the verbalization of events varies significantly depending on the internal features (e.g. aspectual) and external characteristics (e.g. the chronological order) of events.

From these starting points, the current volume contributes to the ongoing discussion about the relevance of empirical and psychological evidence for theoretical-linguistic research and vice versa. The

book is based on the assumption that any research on human language – even from a heuristic perspective – should include insights into procedural aspects in the computation of a linguistic expression. This conception has its roots in the conviction that the ways of processing data from different levels have to be reflected in the linguistic target representation. In reverse, even though theoretical explicitness and fine grained analyses might appear neither manageable nor desirable in the implementation of NLG systems, the integration of more findings from theoretical linguistics into computer science may turn out to be useful in more intricate language production domains.

## **2. The contributions**

The mediating function between concepts and grammar is approached by the contributions to this volume from three interrelated areas of emphasis: i.) the interplay between non-linguistic and linguistic information in the grammaticalization and linearization of a preverbal message, ii.) the mapping between non-linguistic, conceptual event representations and the ways of verbalizing them, and iii.) the mediating function of the lexicon in the verbalization of different types of events. First, questions of the general architecture including the number of levels, specific ways the information is processed on them, and the size and the format of the interface representations is dealt with. Here, the persistence of extra-linguistic information, its visibility for linguistic processes, and its realization in grammar is explored. The interplay of the several types of information involved becomes especially apparent with the issue of event conceptualization and verbalization, which at the same time represents a useful basis for an application of the model assumptions developed so far. Specifically, the question of how event concepts are stored in memory and fractionized for language processing is addressed. In this context, a main issue to be discussed is how grammatical requirements determine the verbalization of event concepts and how the interface can mediate between corresponding informational conflicts. This thematic complex joins together the contributions of the third section. The morpho-syntactic realization of event structural features



and their effects on the assembly of verb complexes is projected from principles organized in the lexicon, which are addressed in the third group of papers. We organize the contributions according to their main focus into the described three sections while at the same time the interrelatedness of the issues dealt with allows for repeated naming of one author in multiple sections. (Authors names appear in bold letters to associate them to a respective section).

**Mediating between non-linguistic and linguistic structures.** The contributions of the first section investigate the influence of different types of extra-linguistic information on the verbalization of a linguistic string. Here, effects on the linearization of a preverbal message are of central interest. This requires a modeling of the incremental realization of the preverbal message as well as a definition of those meaning components which are reflected in grammar. Against this background, FEMKE F. VAN DER MEULEN provides evidence from eye tracking experiments that point to a close link between looking and verbalization. Like Cummins, Gutbrod, and Weingarten, she uses spatial configurations to elicit verbal descriptions. Her data shows that the description of certain types of object arrays is preceded by a preview, which interacts with the viewing times during the main pass of the verbalization. Temporal aspect are of focal importance in the contribution of PHILIP CUMMINS, BORIS GUTBROD, and RÜDIGER WEINGARTEN also, where the complexity of phrasal structures is related to the time course of their production. To show also that additional conceptual information such as the size of the set of concepts to choose from affects the verbalization of spatial configurations, the authors provide evidence from eye-tracking and keyboard data to underpin their hypothesis. The accessibility of conceptually differently weighted constituents is investigated by KATHY Y. VAN NICE and RAINER DIETRICH. They disentangle extra-linguistic features such as animacy and agentivity effects in their impact on word order and develop a model of how this information is carried down through the language production system. The authors thus motivate the incremental processing models as proposed by Guhe as well as Kempen and Harbusch by pointing to the relevance of extra-

linguistic features that become information structurally relevant during processing. MARKUS GUHE proposes an incremental construction of the preverbal message. He explicates how these piecemeal structures link to the underspecified semantic representations (as they are proposed e.g. by Johannes Dölling, Veronika Ehrich, Andreas Späth, and Ladina Tschander). Here, a critical factor is determined, namely, the criterion that need to be fulfilled in order for a conceptual entity to function as a legitimate increment. The incremental processing of information on the syntactic level is central to the work of GERARD KEMPEN and KARIN HARBUSCH, which strongly relies on experimental evidence. They apply a probabilistic method in order to model word order phenomena in the German midfield and indicate that – besides syntactic constraints – information structural conditions are crucial for scrambling. Thereby they mirror the order in which the constituents become accessible for syntactic processing during computation. Considering the referential status of nominal expressions in discourse, aspects of word order are discussed by ANDREAS SPÄTH also. Here, the lexical principles which relate to the syntactic base generation of lexical entries are determined. By means of these principles – as is discussed by Veronika Ehrich and Andrea Schalley also – the link between argument structure and word order is accounted for where informational structural features are included into the computational routines at work between semantics and syntax. With these means presuppositions to be derived from nominal argument phrases can be associated with a current discourse model. From a general architectural perspective, the interaction between grammatically visible and invisible meaning components is investigated by HEIKE WIESE in her tripartite model. Drawing on empirical evidence, she integrates insights from two-level approaches to semantics with conceptual semantics. She advocates semantics as the interface level of the conceptual and the linguistic system, where it is a particular SEM-function that makes visible conceptual information to the linguistic system and generates an under-specified representation.

**Mediating between event conceptualization and verbalization.**

Spatial and temporal configurations are to be linearized during language production. However, while with spatial configurations the multidimensionality of space has to be transferred onto a linear linguistic sequence, with temporal relations the knowledge about the canonical sequential ordering of events such as SOIL–WASH can be employed for structuring the message and thus enhances processing. This latter hypothesis is supported by the findings of ELKE VAN DER MEER, REINHARD BEYER, HERBERT HAGENDORF, DIRK STRAUCH, and MATTHIAS KOLBE, who show in a series of priming experiments that the disruption of the canonical sequence of events as with WASH–SOIL leads to processing difficulties. The authors thus show, how world-knowledge about events has its reflexes in linguistic event descriptions. RALF NÜSE approaches the interrelation between event conceptualization and event verbalization by analyzing language specific differences between English and German speakers. By comparing both linguistic descriptions of visually presented events and the corresponding eye-movements of the speakers, he comes to the conclusion that language specific grammatical features are already at work in the conceptualizer. While she also considers the event domain, a modular conception is supported by MARIA MERCEDES PIÑANGO. She advocates the separation between a semantic and a syntactic module on the basis of the processing event structural variations. She holds that utterances, in which semantic meaning is syntactically transparent are more easily processed than those which are compositionally enriched and thus have to be aspectually coerced into a derived interpretation. This perspective is rejected by JOHANNES DÖLLING. Rather than suggesting a coercion operation for event structurally shifted expressions like *John broke a cup for weeks*, he introduces a parameter which is obligatorily inserted into the semantic representation of any verb complex. Since the parameter is contextually filled, 'coercion' is reinterpreted as contextual enrichment. The idea of enriching linguistic representations by contextual and conceptual information is shared by MARKUS EGG and KRISTINA STRIEGNITZ. However, in the formal realization of this mutual understanding the two approaches differ. For one thing in the

NLG conception of Egg and Striegnitz a context-sensitive *type coercion operator* (TC) is added to the linguistic representation only in specific cases, namely in order to derive a well-formed syntactic structure for expressions containing sortally coerced verb arguments, e.g. *bottle* in *Every bottle froze*.

**The mediating function of the lexicon.** The lexicon is the system where information is stored of how to relate preverbal and linguistic structures in an economic way such that the different communicative requirements accompanying the speech act can be met. Here, a functional perspective is adopted by HEIDRUN DORGELOH and ANJA WANNER. The authors demonstrate that the internal structure of event concepts and their lexical argument structure, respectively, can be made use of to meet register specific requirements. They illustrate how the expression of certain types of events in research articles relate to the degrees of implicitness text producers ascribe to agentive entities. Lexical principles controlling the derivation of nominalizations from different types of verbs are discussed by VERONIKA EHRICH. She shows how different event structural verb types relate to the argument structural behavior of the corresponding nominalizations. While she acknowledges that the interpretation of event nominalizations draws on conceptual knowledge, she insists that the nominal linking rules interfacing syntax and semantics are rooted in the grammatical system, i.e. the lexicon. Lexicon internal event encoding principles are treated by ANDREA C. SCHALLEY, who shares the aspect of language comparison with Ralf Nüse. By exploring data from Walmajarri, Kalam, and German she identifies two competing lexical principles, which are derived from the language specific chunking of event concepts and determine the grammatical alternatives of coding complex events. In the context of motion verbs LADINA B. TSCHANDER investigates the alternation between particle verb constructions versus prepositional phrase constructions. She holds that conceptual conditions associated with motion and path concepts regulate the realization of the corresponding verb complexes. Thereby she accounts for the requirement that goal concepts need to be specified in certain contexts during language production

and shows which lexical properties can adequately realize the corresponding conditions.

## Notes

- \* This volume is the outcome of the workshop *The Syntax-Semantics-Interface: Linguistic Structures and Processes* at the DGfS conference *Language and Cognition* in March 2001. The editors' work on this volume has been completed within the projects *Conceptualization processes in language production* (HA 1237-10) and *Conceptual transfer of situations into verbal meaning and the status of thematic roles* (OL 101-2) of the DFG priority program *Language production* and the project *Semantic interfaces: copula-predicative constructions* at ZAS (Berlin). For constructive comments we wish thank Susan Olsen and we are grateful for the valuable suggestions for improvement that followed from the anonymous review process. For their competent support in the technical realization we are indebted to Britta Görny, Delia Herrn, and Thomas Schulz. Many thanks go to the team of Mouton De Gruyter who were efficient and helpful.
- 1. There exists a vast body of empirical evidence that e.g. many perceptual processes, e.g. in visual perception, are largely autonomous of other cognitive processes (Pylyshyn 1999).
- 2. The remaining three criteria relate to the biological prerequisites of modules and Fodor holds them to be important for discerning module-generated from learned behavior: Modules are *localized*, i.e. mediated by dedicated neural structures. They obey *ontogenetic* and *pathological universals* in that they both mature and decay in distinctive sequences.
- 3. Compare e.g. Frazier (1987) for a strictly modular, and e.g. Bates (1994) for a non-modular view.
- 4. The syntax of a given language is semantically and pragmatically arbitrary. For example, there are no compelling arguments outside syntax for verb-end position in German subordinate clauses.
- 5. A completely different viewpoint is presented by Elman et al. (1996) and Marslen-Wilson & Tyler (1987).
- 6. Here, theories of a generative character like the *Government and Binding Theory* (Chomsky 1981) focus almost exclusively on the representation of argument structure, while there is no consensus on which kind of lexical information is to be included.
- 7. This conviction is shared by theoreticians outside the linking theoretical framework (e.g. Pustejovsky (1992)).
- 8. See Härtl (2003) for discussion.

9. Friederici (1997) discusses corresponding neuro-psychological implications of the assumption that meaning construction is achieved in two steps in language processing.
10. This process has most prominently been accounted for in the *Recognition by Components* or *Geon Theory* (cf. Biederman 1995). It posits that objects and scenes are represented as an arrangement of simple, viewpoint-invariant volumetric primitives (e.g. bricks, cylinders, wedges, and cones) termed geons that are recognizable even if parts are occluded. Geon theory has been extensively tested and can elegantly account for the fact that objects become hardly recognizable when viewed from a highly unfamiliar perspective. A leading alternative view to recognition by components is proposed by *View-Based Recognition* approaches (cf. e.g. Tarr & Bülthoff 1995).
11. These processes can be characterized as follows: *Segmentation* of states of affairs is the distinction of those entities that are relevant within a current conceptualization, especially temporal and spatial segmentation. *Structuring* of states of affairs leads to the construction of hierarchical event structures. *Selection* singles out the subclass of available entities that are to be verbalized (cf. Habel & Tappe 1999).
12. Following Härtl (2001: 109) we assume that during language production the first component of the language production system, the so called *conceptualizer*, has access to the currently activated information from both the semantic and the episodic knowledge base. Thus concrete episodic information (including temporal and spatial specifications) can be linked to global information about abstract event types (including abstract temporal and spatial structures)
13. Here we find a striking analogy to computational language production models: Computer linguists have so far been forced to content themselves with very restricted domains in order to build running systems, in which a coupling between the to-be-verbalized contents and language output can be guaranteed.
14. Cf. Pechmann (in print) for an overview of experimental methods in language production research.
15. Similar trends are witnessed in linguistics, e.g. in conceptions of the *generative lexicon* (Pustejovsky 1995) and also in the *minimalist program* (Chomsky 1995, 2000).

## References

- Aduciewicz, Kazimierz  
 1935 Die syntaktische Konnexität. *Studia Philosophica* 1, 1–27.

- Anderson, John R.  
1991 The adaptive nature of human categorization. *Psychological Review* 98: 409–429.
- Baker, Mark  
1997 Thematic roles and syntactic structure. In: Liliane Haegeman (ed.), *Elements of Grammar*, 73–137. Dordrecht, Kluwer..
- Barsalou, Lawrence W., Wenchi Yeh, Barbara J. Luka, Karen L. Olseth, Kelly S. Mix and Ling-Ling Wu  
1993 Concepts and meaning. In: Katharine Beals, Gina Cooke, David Kathman, Karl-Erik McCullough, Sotaro Kita and David Testen (eds.), *Chicago Linguistics Society 29: Papers from the parasession on conceptual representations*, 23–61. University of Chicago: Chicago Linguistics Society.
- Barwise, Jon and John Perry  
1983 *Situations and Attitudes*. Cambridge, MA: MIT Press.
- Bates, Elizabeth  
1994 Modularity, domain specificity and the development of language. In: *Discussions in Neuroscience* 10: 136–149.
- Bates, Elizabeth and Brian MacWhinney  
1984 *Cross-linguistic Studies of Sentence Processing*. Cambridge: Cambridge University Press.
- Bäuerle, Rainer  
1985 Das Lexikon in der kompositionalen Semantik. In: Christoph Schwarze and Dieter Wunderlich (eds.), *Handbuch der Lexikologie*, 199–229. Königstein, Ts.: Athenäum.
- Berwick, Robert C. and Amy S. Weinberg  
1984 *The Grammatical Basis of Linguistic Performance*. Cambridge, MA: MIT Press.
- Bickerton, Derek  
1990 *Language and Species*. Chicago: University of Chicago Press.
- Biederman, Irving  
1995 Visual object recognition. In: Stephen M. Kosslyn and Daniel N. Osherson (eds.), *An Invitation to Cognitive Science, 2nd edition, Vol. 2, Visual Cognition*, 121–165. Cambridge, MA: MIT Press.
- Bierwisch, Manfred  
1983 Semantische und konzeptionelle Repräsentationen lexikalischer Einheiten. In: Rudolf Ruzicka and Wolfgang Motsch (eds.), *Untersuchungen zur Semantik (Studia Grammatika 22)*, 61–89. Berlin: Akademie-Verlag.  
1986 On the nature of semantic form in natural language. In: Friedhart Klix and Herbert Hagendorf (eds.), *Human Memory and Cognitive Capabilities – Mechanisms and Performances*, 765–784. Vol. B. Amsterdam: Elsevier.

- Bierwisch, Manfred and Rob Schreuder  
1992 From concepts to lexical items. *Cognition* 4: 23–60.
- Bloom, Paul  
1998 Theories of artifact categorization. *Cognition* 66: 87–93.
- Brody, Michael and M. Rita Manzini  
1988 On implicit arguments. In: Ruth Kempson (ed.), *Mental Representations: The Interfaces between Language and Reality*, 105–130. Cambridge: Cambridge University Press.
- Busemann, Stephan  
1993 A holistic view of lexical choice. In: Helmut Horacek (ed.), *New Concepts in Natural Language Generation: Planning, Realization, and Systems*, 302–308. London, New York: Frances Pinter.
- Caramazza, Alfonso  
1997 Brain and language. In: Michael S. Gazzaniga (ed.), *Conversations in the Cognitive Neurosciences*, 131–151. Cambridge, MA: MIT Press.
- Chomsky, Noam  
1981 *Lectures on Government and Binding*. Dordrecht: Foris Publications.  
1986 *Knowledge of Language: Its Nature, Origin and Use*. New York: Praeger.  
1993 A minimalist program for linguistic theory. In: Kenneth Hale and Samuel J. Keyser (eds.), *The view from Building 20*, 1–52. Cambridge, MA: MIT Press.  
1995 *The Minimalist Program*. Cambridge, MA: MIT Press.  
2000 Minimalist inquiries: The framework. In: Roger Martin, David Michaels and Juan Uriagereka (eds.), *Step by Step*. Cambridge, MA: MIT Press.
- Cresswell, Maxwell J.  
1978 Semantic competence. In: Franz Guenther and M. Guenther-Reutter (eds.), *Meaning and Translation*, 9–27. London: Duckworth.
- De Smedt, Koenraad, Helmut Horacek, and Michael Zock  
1996 Architectures for natural language generation: Problems and perspectives. In: Giovanni Adorni and Michael Zock (eds.), *Trends in Natural Language Generation: An Artificial Intelligence Perspective* (Springer lecture notes in artificial intelligence 1036), 17–46. Berlin: Springer.
- Deane, Paul D.  
1992 *Grammar in Mind and Brain*. Berlin, New York: Mouton de Gruyter.
- Dölling, Johannes  
1998 Semantic form and abductive fixation of parameters. Ms. Universität Leipzig.
- Dowty, David R.  
1979 *Word Meaning and Montague Grammar*. Reidel, Dordrecht.



- Ehrich, Veronika  
1992 *Hier und jetzt: Studien zur lokalen und temporalen Deixis im Deutschen*. Tübingen: Niemeyer
- Elman, Jeffrey L., Elizabeth A. Bates, Mark H. Johnson, Annette Karmiloff-Smith, Domenico Parisi and Kim Plunkett  
1996 *Rethinking Innateness*. MIT Press.
- Fodor, Jerry A.  
1983 *The Modularity of Mind. An Essay on Faculty Psychology*. Cambridge, MA: MIT Press  
1998 The trouble with psychological Darwinism. *London review of books*. Vol. 20, 2. [<http://www.lrb.co.uk/v20n02/fodo2002.html>]
- Frazier, Lyn  
1987a Sentence processing: A tutorial review. In: Max Coltheart (ed.), *Attention and Performance XII: The Psychology of Reading*. Hillsdale: Lawrence Erlbaum.  
1987b Theorie of sentence processing. In: Jay L. Garfield (ed.), *Modularity in Knowledge Representation and Natural Language Understanding*. Cambridge, MA: MIT Press.
- Frazier, Lyn, Charles Clifton and Janet Randall  
1983 Filling gaps: Decision principles and structure in sentence comprehension. *Cognition* 13: 187–222.
- Friederici, Angela D.  
1997 Neurophysiological aspects of language processing. *Clinical Neuroscience* 4: 64–72.
- Gärdenfors, Peter  
2000 *Conceptual Spaces*. Bradford Books. Cambridge, MA: MIT Press
- Gazdar, Gerald, Ewan Klein, Geoffrey Pullum and Ivan Sag  
1985 *Generalized Phrase Structure Grammar*. Oxford: Basil Blackwell.
- Grimshaw, Jane  
1979 Complement selection and the lexicon. *Linguistic Inquiry* 10: 279–326.  
1990 *Argument Structure*. Cambridge, MA: MIT Press.  
1993 Semantic structure and semantic content in lexical representation. Unpublished ms., Rutgers University, New Brunswick, NJ.
- Grimshaw, Jane and Sten Vikner  
1993 Obligatory adjuncts and the structure of events. In: Eric Reuland and Werner Abraham (eds.), *Knowledge and Language: Vol. II: Lexical and Conceptual Structure*, 145–159. Dordrecht: Kluwer.
- Habel, Christopher and Heike Tappe  
1999 Processes of segmentation and linearization in describing events. In: Ralf Klabunde and Christiane v. Stutterheim (eds.), *Representations and processes in language production*, 117–153. Wiesbaden: Deutscher Universitätsverlag.

Härtl, Holden

- 2001 *CAUSE und CHANGE: Thematische Relationen und Ereignisstrukturen in Konzeptualisierung und Grammatikalisierung*. (Studia Grammatica 50). Berlin: Akademie-Verlag.
- 2003 Conceptual and grammatical characteristics of argument alternations: The case of decausative verbs. Appears in: *Linguistics* 41(5).

Jackendoff, Ray

- 1972 *Semantic Interpretation in Generative Grammar*. Cambridge, MA: MIT Press.
- 1990 *Semantic Structures*. Cambridge, MA: MIT Press
- 1992 *Languages of the Mind*. Cambridge, MA: MIT Press.
- 1997 *The Architecture of the Language Faculty*. Cambridge, MA: MIT Press.

Jescheniak, Jörg D. and Willem J. M. Levelt

- 1994 Word frequency in speech production: Retrieval of syntactic information and phonological form. *Journal of Experimental Psychology: Learning, Memory and Cognition* 20: 824–843.

Kaplan, David

- 1977 The logic of demonstratives. *Journal of Philosophical Logic* 8: 81–98.

Kaplan, Ronald M. and Joan Bresnan

- 1982 Lexical-functional grammar: A formal system for grammatical representation. In: Joan Bresnan (ed.), *The Mental Representation of Grammatical Relations*. Cambridge, MA: MIT Press.

Karmiloff-Smith, Annette

- 1992 *Beyond Modularity: A Developmental Perspective on Cognitive Science*. Cambridge, MA: MIT Press.

Katz, Jerrold J. and Jerry A. Fodor

- 1963 The structure of a semantic theory. *Language* 39: 170–210.

Koenig, Jean-Pierre and Gail Mauner

- 1999 A-definites and the semantics of implicit arguments. *Journal of Semantics* 16: 207–236.

Lakoff, George

- 1991 Metaphor and war: The metaphor system used to justify war in the Gulf. Distributed via electronic bulletin boards. *Journal of Urban and Cultural Studies* 2.

Lang, Ewald

- 1994 Semantische und konzeptuelle Struktur: Unterschneidung und Überschneidung. In: Monika Schwarz (ed.), *Kognitive Semantik: Ergebnisse, Probleme, Perspektiven*, 25–41. Tübingen: Narr.

Langacker, Ronald W.

- 1987 *Foundations of Cognitive Grammar I: Theoretical Prerequisites*. Stanford: Stanford University Press.

- 1990 Settings, participants, and grammatical relations. In: S. Tsohatzidis (ed.), *Meanings and Prototypes: Studies in Linguistic Categorization*, 213–238. New York: Routledge, Chapman and Hall.
- 1991 *Foundations of Cognitive Grammar II: Descriptive Applications*. Stanford: Stanford University Press.
- Levelt, Willem J. M.  
1989 *Speaking: From Intention to Articulation*. Cambridge, MA, London, UK: MIT Press.
- Levelt, Willem J. M., Ardi Roelofs and Antje S. Meyer  
1999 A theory of lexical access in speech production. *Behavioral and Brain Sciences* 22: 1–75.
- Levinson, Stephen C.  
1996 Frames of reference and Molyneaux's question: Cross-linguistic evidence. In: Paul Bloom, Mary A. Peterson, Lynn Nadel and Merrill F. Garrett (eds.), *Language and Space*, 109–169. MIT Press.
- Levin, Beth and Malka Rappaport Hovav  
1995 *Unaccusativity: At the Syntax-Lexical Semantics Interface*. (Linguistic Inquiry Monograph 26). Cambridge, MA: MIT Press.
- Lewis, David  
1972 Psychophysical and theoretical identifications. *Australasian Journal of Philosophy* 50: 249–258.
- Marcus, Mitchell P.  
1982 Consequences of functional deficits in a parsing model: Implications for Broca's aphasia. In: Michael A. Arbib, David Caplan, John C. Marshall (eds.), *Neural Models of Language Processes (Perspectives in Neurolinguistics, Neuropsychology, and Psycholinguistics)*, 115–134. New York: Academic Press.
- Marshall, John C.  
1984 Multiple perspectives on modularity. *Cognition* 17: 209–242.
- Marslen-Wilson, William D. and Lorraine K. Tyler  
1987 Against modularity. In: Jay L. Garfield (ed.), *Modularity in Knowledge Representation and Natural-Language Understanding*. Cambridge, MA: MIT Press.
- McCawley, James D.  
1971 Tense and time reference in English. In: Charles Fillmore and D. Terence Langendoen (eds.), *Studies in Linguistic Semantics*, 97–113. New York: Holt Rinehart.
- McShane, Marjorie and Ron Zacharski  
2001 Modularity in knowledge elicitation and language processing. *Proceedings of the Third Annual High Desert Linguistics Conference*. University of New Mexico, Albuquerque NM, April 7–9, 2000. 93–104.

- Medin, Douglas L.  
1989 Concepts and conceptual structure. *American Psychologist* 44: 1469–1481.
- Meisel, Jürgen M. (ed.)  
1990 *Two First Languages: Early Grammatical Development in Bilingual Children*. Dordrecht: Foris.
- Mohanan, Tara and Lionel Wee (eds.)  
1999 *Grammatical Semantics: Evidence for Structure in Meaning*. Stanford, CA: CSLI Lecture Notes.
- Montague, Richard  
1970 Universal grammar. *Theoria* 36, 373–398.
- Montague, Richard  
1973 The proper treatment of quantification in ordinary English. In: Jaakko Hintikka, Julius M. Moravcsik and Patrick Suppes (eds.), *Approaches to Natural-Language: Proceedings of the 1970 Stanford Workshop on Grammar and Semantics*, 221–242. Dordrecht: Reidel. [Reprinted in Montague (1974). 247–270.].
- Müller, Ralph-Axel  
1996 Innateness, autonomy, universality? Neurobiological approaches to language. *Behavioral and Brain Sciences* 19: 611–675.
- Newmeyer, Frederick J.  
1998 *Language Form and Language Function*. Cambridge, MA: MIT Press.
- O'Bryan, Erin, Raffaella Folli, Heidi Harley and Thomas Bever  
in prep. The Role of Event Structure in Language Comprehension,  
[http://www.ling-phil.ox.ac.uk/research/folli/research\\_files/amlap.doc](http://www.ling-phil.ox.ac.uk/research/folli/research_files/amlap.doc)
- Olsen, Susan  
1998 Prädikative Argumente syntaktischer und lexikalischer Köpfe: Partikelverben im Deutschen und Englischen. *Folia Linguistica* 31: 301–329.
- Partee, Barbara  
1975 Montague grammar and transformational grammar. *Linguistic Inquiry* 6(2): 203–300.
- Pechmann, Thomas  
in print Experimentelle Methoden in der Sprachproduktionsforschung. In: Theo Herrmann and Joachim Grabowski (eds.), *Enzyklopädie der Psychologie, Band C III/1: Sprachproduktion*. Göttingen: Verlag für Psychologie.
- Pollard, Carl and Ivan Sag  
1987 *An Information-based Approach to Syntax and Semantics: Vol. 1 Fundamentals*. Stanford, CA: CSLI Lecture Notes.
- Pustejovsky, James  
1995 *The Generative Lexicon*. Cambridge, MA: MIT Press.

- Pylyshyn, Zenon W.  
1999 Is vision continuous with cognition? The case for cognitive impenetrability of visual perception. *Behavioral and Brain Sciences* 22(3): 341–423.
- Rappaport, Malka and Beth Levin  
1988 What to do with theta-roles. In: Wendy Wilkins (ed.), *Syntax and Semantics 21: Thematic Relations*, 7–36. New York, NY: Academic Press.
- Roeper, Thomas  
1987 Implicit arguments and the head-complement relation. *Linguistic Inquiry* 18: 267–310.
- Saussure, Ferdinand de  
1916 *Cours de linguistique générale*. In: Charles Bally and Albert Sechehaye (eds.), Paris: Payot.
- Smolensky, Paul  
1988 On the proper treatment of connectionism. *Behavioral and Brain Sciences* 11: 1–74.
- Stillings, Neil A.; Steven E. Weisler, Christopher H. Chase, Mark H. Feinstein, Jay L. Garfield and Edwina L. Rissland  
1998 *Cognitive Science: An Introduction* (2nd ed.). Cambridge, MA: MIT Press.
- Stromswold, Karin  
1992 Learnability and the acquisition of auxiliary and copula *be*. In: *ESCOL '91*. Columbus State University.
- Tappe, Heike  
1999 *Der Spracherwerb bei Corpus-Callosum-Agenesie: Eine explorative Studie*. Tübingen: Narr.  
2000 Perspektivenwahl in Beschreibungen dynamischer und statischer Wegesketten. In: Christopher Habel and Christiane v. Stutterheim (eds.), *Räumliche Konzepte und sprachliche Strukturen*, 69–97. Tübingen: Niemeyer.
- Tarsky, Alfred  
1977 *Einführung in die Mathematische Logik*. Göttingen: Vandenhoeck and Ruprecht.
- Tarr, Michael J. and Heinrich H. Bühlhoff  
1995 Is human object recognition better described by geon structural descriptions or by multiple views? Comment on Biederman and Gerhardstein (1993). *Journal of Experimental Psychology: Human Perception and Performance*. 21(6): 1494–1505.
- Taylor, Holly A. and Barbara Tversky  
1996 Perspective in spatial descriptions. *Journal of Memory and Language* 35, 371–391.

Tenny, Carol

1992 The Aspectual Interface Hypothesis. In: Ivan A. Sag and Anna Szabolcsi (eds.), *Lexical Matters* (CSLI lecture notes 24), 1–27. Palo Alto: Stanford University Press.

1994 *Aspectual Roles and the Syntax-Semantics Interface*. (Studies in Linguistics and Philosophy 52). Dordrecht: Kluwer.

Tomasello, Michael

2000a Do young children have adult syntactic competence? *Cognition* 74: 209–253.

2000b The item based nature of children's early syntactic development. *Trends in Cognitive Sciences* 4: 156–163.

van Hout, Angeliek

1996 Event semantics of verb frame alternations: A case study of Dutch and its acquisition. Ph.D. dissertation, Tilburg University.

Wilder, Chris and Damir Cavar

1994 Long head movement? Verb movement and cliticization in croatian. *Lingua* 93: 1–58

Wunderlich, Dieter

1997 CAUSE and the structure of verbs. *Linguistic Inquiry* 28(1): 27–68.

Zacks, Jeffrey M.

1997 Seeing the structure in events. Ms., Stanford University.

Zeevat, Henk, Ewan Klein and Jo Calder

1987 *Unification categorial grammar*. In: Nicholas Haddock, Ewan Klein and Glyn Morrill (eds.), *Categorial Grammar, Unification Grammar, and Parsing*. University of Edinburgh, Scotland.